

ECLIPSE 705

Guided Wave Radar Level Transmitter

FOR HYGIENIC USE

DESCRIPTION

The Eclipse® 705 Transmitter is a loop-powered, 24 V DC liquid-level transmitter based on the revolutionary Guided Wave Radar (GWR) technology. Encompassing a number of significant engineering accomplishments, this leading edge level transmitter is designed to provide measurement performance well beyond that of many traditional technologies, including “through-air” radar.

The Eclipse® 705 offers enhanced reliability, as demonstrated by a Safe Failure Fraction of 91 %.

FEATURES

- * “REAL LEVEL”, measurement not affected by media variables eg. dielectrics, pressure, density, pH, viscosity, ...
- * Can measure reliably to very top of vessel and to the bottom of the probe.
- * Two-wire, intrinsically safe loop powered level transmitter.
- * 20-point custom strapping table for volumetric output.
- * Housing can be removed without depressurising the vessel.
- * Two-line, 8-character LCD and 3-button keypad.
- * Suitable design for CIP/SIP cleaning.
- * Integral or remote electronics.
- * Suited for SIL 2 / SIL 3 Loops (full FMEDA report and certificate available).
- * Designed to Bio Processing Equipment (BPE) standards.
- * The certificate of conformity includes certification of 'O'-rings, PTFE, TFE, and PEEK as 21CFR-177 GRAS and USP <88> Class VI at 121 °C, and metallic material CMTR's and surface finish specification.

APPLICATIONS

MEDIA: From non conductive liquids up to water-based media (dielectric 1,9 - 100).

VESSELS: Most process or storage vessels.

CONDITIONS: All level measurement and control applications including process conditions exhibiting visible vapours, foam, surface agitation, bubbling or boiling, high fill/empty rates, low level and varying dielectric media or specific gravity.

Measures real «LEVEL, VOLUME, INTERFACE»

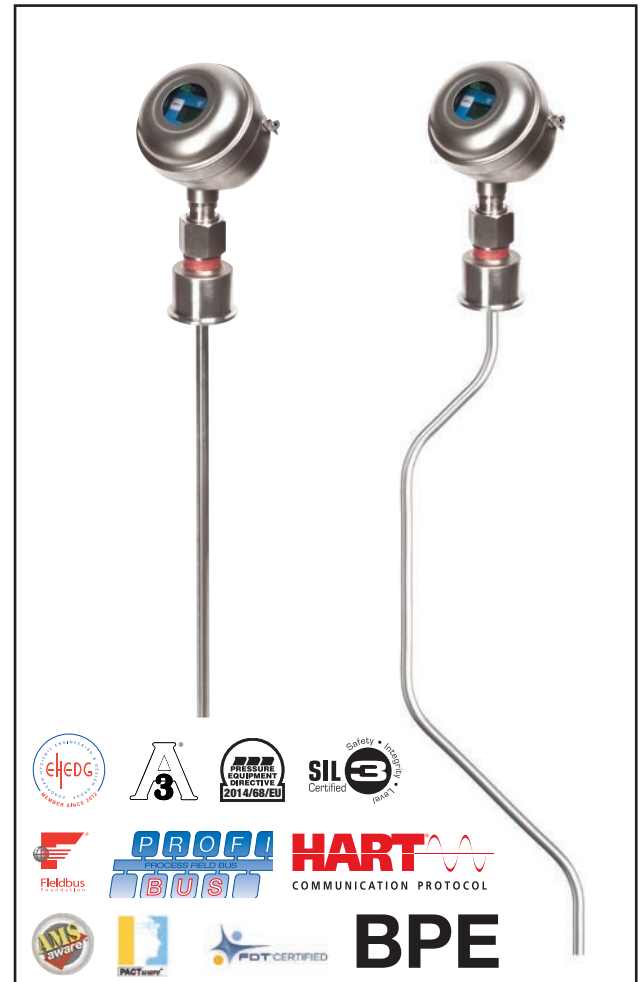

AGENCY APPROVALS

Agency	Approvals
ATEX	II 1 G Ex ia IIC T4 Ga, intrinsically safe II 1 G Ex ia IIC T4 Ga, FISCO – intrinsically safe ①
TNO	Hygienic Machinery Directive 98/37/EC annex 1, section 2,1 EN 1672 part 2, Hygienic requirements EHEDG doc. 2 (second edit. March 2000) and doc. 8 (July 1993)
FM/CSA ②	
IEC ②	
Russian Authorisation Standards ②	
Other approvals are available, consult factory for more details	

① FOUNDATION Fieldbus™ and Profibus PA™ units

② Consult factory for proper model numbers and classifications

TECHNOLOGY

Eclipse® Guided Wave Radar is based upon the technology of TDR (Time Domain Reflectometry). TDR utilises pulses of electromagnetic energy transmitted down a wave guide (probe). When a pulse reaches a liquid surface that has a higher dielectric constant than the air (ϵ_r of 1) in which it is traveling, the pulse is reflected. The travelling time of the pulse is measured via ultra high speed timing circuitry that provides an accurate measure of the liquid level.

Principle of operation

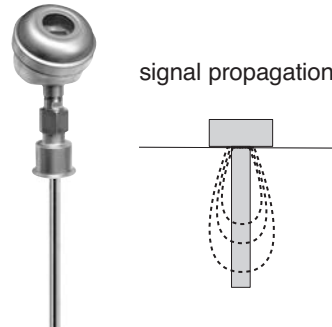
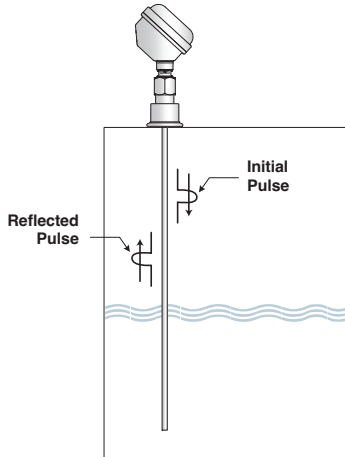

PACTware™ PC SOFTWARE PROGRAM

FDT technology provides an open communication interface between field instruments of various communication protocols and the host/ DCS system. The DTM driver is typical for one type of instrument and delivers the full functionality of the device added with graphical user interface via a laptop or PC. Magnetrol transmitters use the free shareware PACTware™ software to support DTM drivers and the FDT functionality. Via PACTware™ it becomes easy to configure, monitor and diagnose a Magnetrol transmitter from distance or even to call for factory assistance over the internet via the supply of screenshots of echo curves and trending graphs. Magnetrol DTM library HART® has passed the dtmINSPECTOR, the official FDT interoperability test and certification tool. The Magnetrol DTM's are free of charge and can be downloaded from www.magnetrol.com.



PROBE & HOUSING FEATURES



Stainless steel housing with probe

Eclipse model 705 transmitter in a 304 stainless steel housing for use in a variety of hygienic applications. The probe has a $0,4 \mu\text{m Ra}$ (15 Ra) electropolished surface finish and is available with 3/4" through 3" Tri-Clamp® process connections. Other process connections are available upon request.



1 1/2" Tri-Clamp® connection with bend

Multiple bending allows the rod to be profiled to any tank shape. Measurement is possible down to the probe tip, eliminating the "dead" volume in the bottom of a tank that cannot usually be measured.



3/4" Tri-Clamp® connection without bend

6 mm (0.25") diameter probes suitable for use in smaller vessels where space is at a premium. Available in lengths up to 180 cm (72").



Segmented Hygienic Probe

Segmented probes are available should the probe be inserted or removed with limited headroom above the vessel (segmented lengths are specified by the customer). Contact the factory for details.



Stainless steel housing

Compact, single compartment, 304 stainless steel housing with a $0,82 \mu\text{m Ra}$ (32 Ra) surface finish.

MOUNTING CONSIDERATIONS FOR SINGLE ROD GWR PROBES

1. Turbulence

The bottom of the probe should be stabilised if turbulence will cause a deflection of more than 75 mm at 3 m (3" at 10') of length. The probe should not make contact with the side wall of a metal tank. The use of a capture ring at the lowest point on the probe will prevent unwanted probe movement, while maintaining cleanability.

2. Nozzles: do not restrict the performance by ensuring the following:

1. Nozzle must be 19 mm (3/4") diameter **(A)** or larger.
2. Nozzle inside diameter **(A)** should be \geq to nozzle height **(B)**. If this is not the case, it is recommended to adjust BLOCKING DISTANCE and/or SENSITIVITY settings.

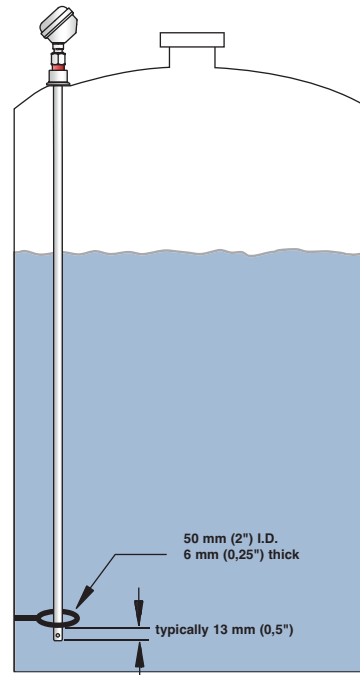
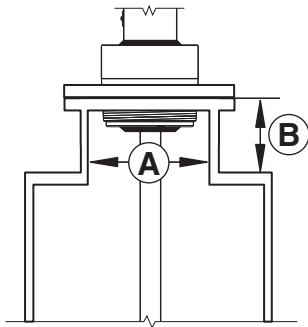

3. Metallic (conductive) obstructions in tank

A metal stillwell/cage of max. 6"/DN150 size or a metal tank wall within 450 mm (18") of the probe mounting will allow the unit operate accurately in media with dielectrics down to ϵ_r 1.9.

Note: objects (eg. shoulders or agitator blades) can be within 6 mm (1/4"), if Pactware is used for loop tuning.

Distance to probe	Acceptable objects
< 13 mm (0.5")	Continuous, smooth, parallel, conductive surface (e.g. metal tank wall); probe should not touch tank wall

4. Non-metallic vessels

1. Flange (metal) mounting is recommended for optimum performance.
2. Mount probe more than 13 mm (0.5") from vessel-wall.

HYGIENIC APPLICATION EXAMPLES

The model 705 transmitters are presently installed in a variety of media systems including bioreactors, fermenters, media storage, crystallisers, decanters, ultra filtration skid receivers, cook kettles, CIP systems, balance tanks, mixing tanks, storage tanks, etc.

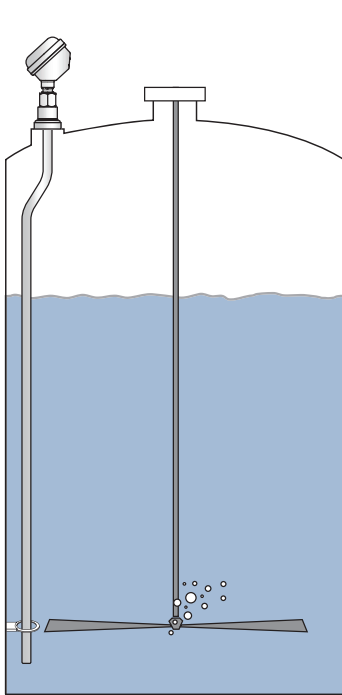

Reactor

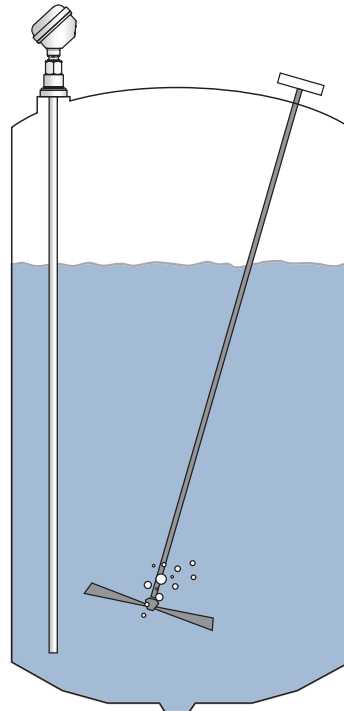

Fermentor or mix tank

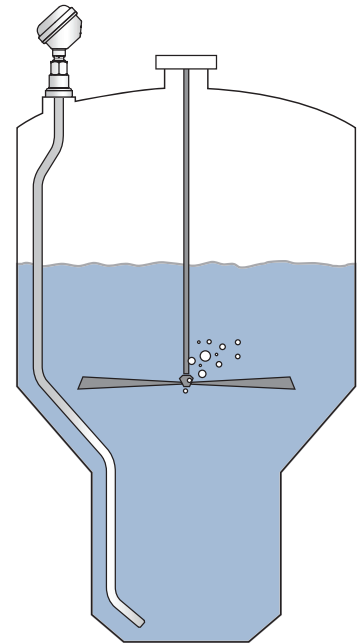

Tulip tank

Buffers systems including:

- primary mix tanks
- hold tanks
- day tanks
- bulk tanks

CIP systems including:

- day tanks
- bulk tanks
- skid delivery tanks

Utility systems including:

- ammonia storage
- CO₂ storage
- inlet water
- dearator systems
- condensate receivers
- boiler drums
- fuel oil storage
- various sumps
- waste tanks
- neutralisation tanks

Refer to bulletin BE 57-101 and BE 57-102 for appropriate probe selection.

DIMENSIONS in mm (inches)

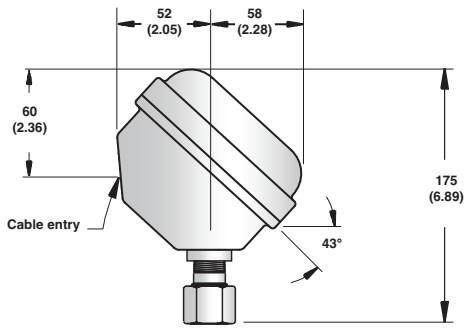

Integral Electronics

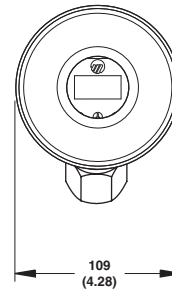

43° View

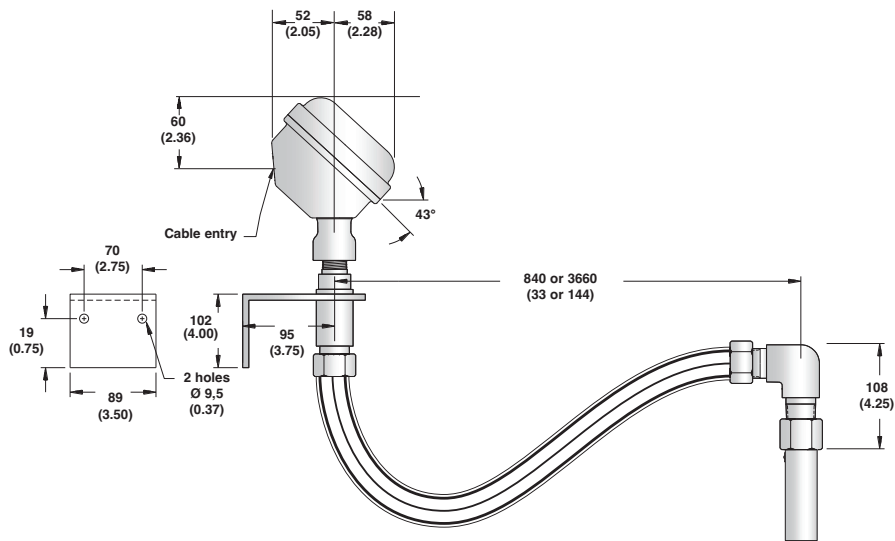

Remote Electronics

ELECTRICAL WIRING

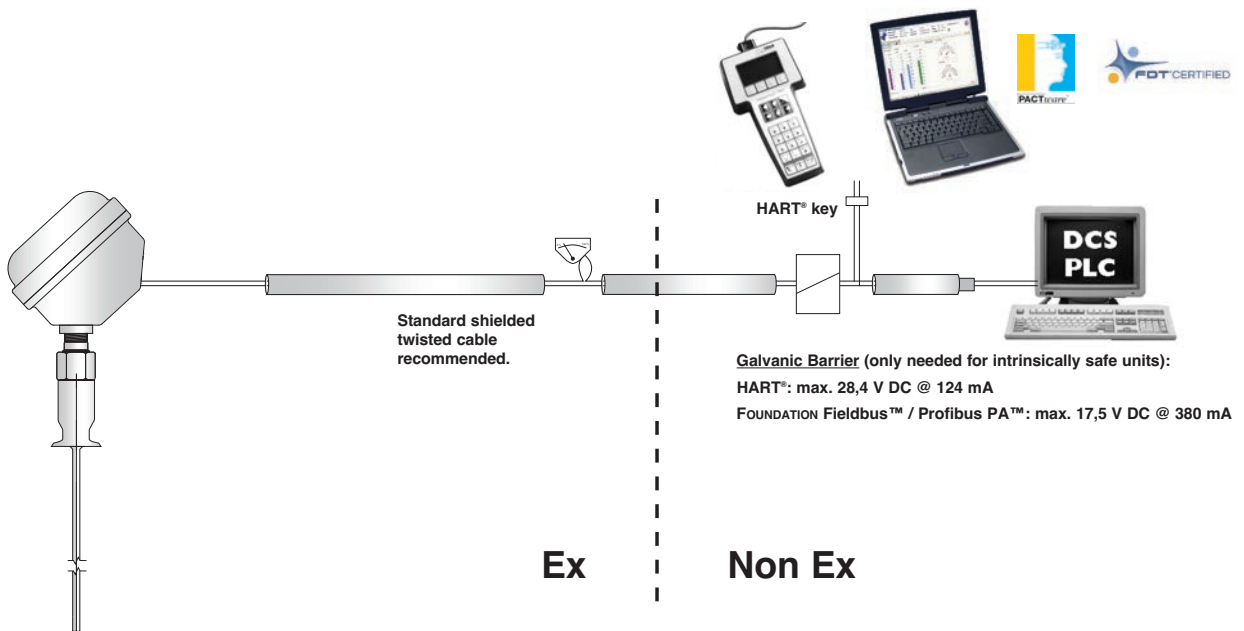

SELECTION DATA

A complete measuring system consists of:

1. Eclipse 705 transmitter head/electronics
2. Eclipse 705 GWR probe
3. Free of charge: Eclipse 705 DTM (PACTware™) can be downloaded from www.magnetrol.com.
4. Option: MACTek Viator USB HART® interface: order code: **070-3004-002**

1. Order code for ECLIPSE 705 transmitter head/electronics

1 - 3 | BASIC MODEL NUMBER

7	0	5	Eclipse 705 guided wave radar transmitter
---	---	---	---

4 | POWER

5	24 V DC, two wire loop powered
---	--------------------------------

5 6 | OUTPUT AND ELECTRONICS

1	0	4-20 mA with HART® – standard electronics (SFF of 84,5 %)
1	A	4-20 mA with HART® – SIL enhanced electronics (SFF of 91 %) – certified ^①
2	0	FOUNDATION Fieldbus™ communication
3	0	Profibus PA™ communication

^① Not available with 7MH probe.

7 | ACCESSORIES

A	Housing cover with glass window
0	Blind housing cover

8 9 | MOUNTING / HOUSING MATERIAL / APPROVAL ^{② ③}

Integral mount electronics

304 SST – IP 67

1	3	Weatherproof
A	3	ATEX intrinsically safe (digit 5 = 1) / ATEX FISCO (digit 5 = 2 or 3)

84 cm (33") remote mount electronics

304 SST – IP 67

2	3	Weatherproof
B	3	ATEX intrinsically safe (digit 5 = 1) / ATEX FISCO (digit 5 = 2 or 3)

3,66 m (144") remote mount electronics (consult factory for applications with $\epsilon_r < 10$)

304 SST – IP 67

2	9	Weatherproof
B	9	ATEX intrinsically safe (digit 5 = 1) / ATEX FISCO (digit 5 = 2 or 3)

^② Other housing materials / approvals are available; refer to bulletin BE 57-101.

^③ Consult factory for FM, CSA or other approvals.

10 | CABLE ENTRY

1	M20 x 1,5 (2 entries – 1 plugged)
---	-----------------------------------

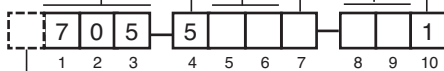

complete order code for ECLIPSE 705 transmitter head/electronics

➔ X = product with a specific customer requirement

DIMENSIONS in mm (inches)

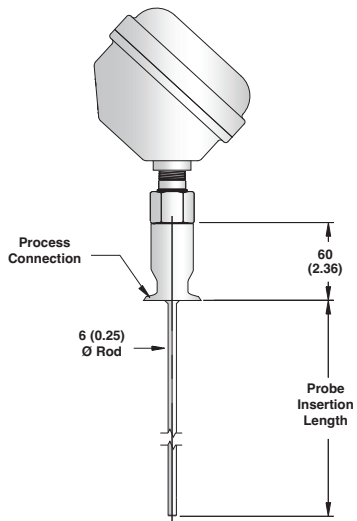

3/4" Tri-Clamp® connection
max. 1,80 m (72")

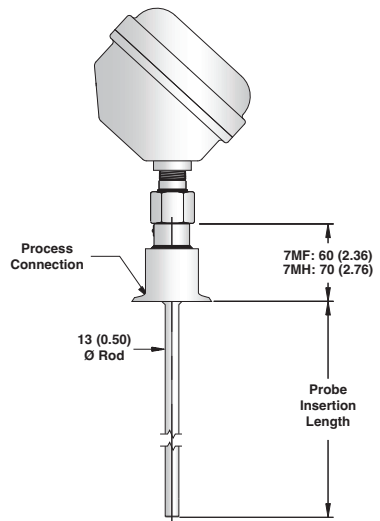

All except 3/4" Tri-Clamp® connection
max. 6,10 m (240")

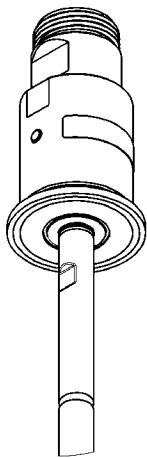

Tri-Clamp®

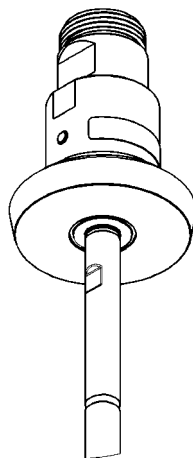

DIN 11851

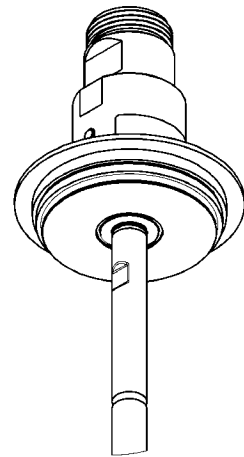

Varivent

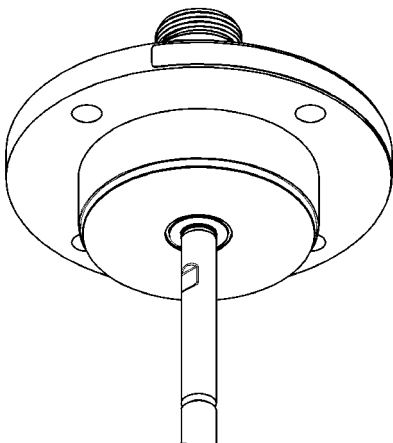

NEUMO BioControl

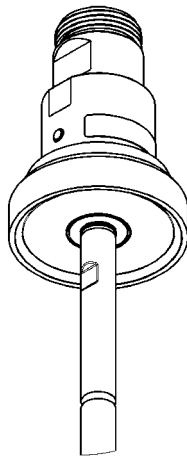

DIN 11864-1 Type A

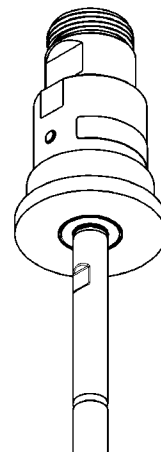

SMS

2. Order code for ECLIPSE 705 - hygienic GWR probe for liquids

1 - 3 | BASIC MODEL NUMBER

7 M F	Hygienic single rod with PTFE seal	(dielectric range: $\geq 1,9/10$) ^①
-------	------------------------------------	---

^① See mounting considerations on page 4 for $\epsilon_r \geq 1,9$ and < 10 .

4 | PROBE MATERIAL (0,4 μm Ra (15 Ra) electropolished surface finish)

E	316/316L (1.4401/1.4404) stainless steel
G	AL-6XN stainless steel (UNS N08367)
H	Hastelloy® C22 (2.4602)

5 6 7 | PROCESS CONNECTION - SIZE/TYPE

2 P N	3/4" Tri-Clamp®
3 P N	1" - 1 1/2" Tri-Clamp®
4 P N	2" Tri-Clamp®
9 P N	2 1/2" Tri-Clamp®
5 P N	3" Tri-Clamp®
6 P N	4" Tri-Clamp®

8 9 10 | INSERTION LENGTH – Specify insertion length per cm (0.39") increment

0 3 0	minimum 30 cm (12")
1 8 0	maximum 180 cm (72") for 3/4" process conn. size
6 1 0	maximum 610 cm (240") for 1" up to 4" process conn. size

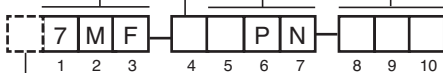

complete order code for ECLIPSE hygienic GWR probe

X = product with a specific customer requirement

1 - 3 | BASIC MODEL NUMBER

7 M H	Hygienic single rod with PEEK® & 'O'-ring seal	(dielectric range: $\geq 1,9/10$) ^②
-------	--	---

^② See mounting considerations on page 4 for $\epsilon_r \geq 1,9$ and < 10 .

4 | PROBE MATERIAL (0,4 μm Ra (15 Ra) electropolished surface finish)

E	316/316L (1.4401/1.4404) stainless steel
G	AL-6XN stainless steel (UNS N08367)
H	Hastelloy® C22 (2.4602)
L	316L (1.4435) stainless steel

5 6 | PROCESS CONNECTION - SIZE/TYPE

3 P	1" - 1 1/2" Tri-Clamp®
4 P	2" Tri-Clamp®
9 P	2 1/2" Tri-Clamp®
5 P	3" Tri-Clamp®
6 P	4" Tri-Clamp®
C S	DN 40 DIN 11851
D S	DN 50 DIN 11851
V V	Varivent Type N (mounting diameter 68 mm)
D N	D 50 NEUMO BioControl
V N	D 65 NEUMO BioControl
E N	D 80 NEUMO BioControl
D R	DN 50 DIN 11864-1 Type A
S Y	DN 1 1/2" SMS
T Y	DN 2" SMS

7 | PROCESS SEAL MATERIAL

C	PEEK® & Viton® GF 'O'-rings	-40 °C (-40 °F) / +150 °C (+300 °F)
1	PEEK® & EPDM 'O'-rings	-40 °C (-40 °F) / +120 °C (+250 °F)

8 9 10 | INSERTION LENGTH – Specify insertion length per cm (0.39") increment

0 3 0	minimum 30 cm (12")
6 1 0	maximum 610 cm (240")

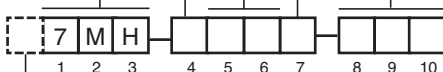

complete order code for ECLIPSE hygienic GWR probe

X = product with a specific customer requirement

TRANSMITTER SPECIFICATIONS

FUNCTIONAL/PHYSICAL

Description		Specification
Power (at terminals)		HART® + weatherproof: 11 to 36 V DC HART® + ATEX Intrinsically Safe: 11 to 28,4 V DC FOUNDATION Fieldbus™ / Profibus PA™ + weatherproof: 9 to 32 V DC FOUNDATION Fieldbus™ / Profibus PA™ + ATEX FISCO: 9 to 17,5 V DC
Output		4-20 mA with HART®, 3,8 mA to 20,5 mA useable (meets NAMUR NE 43) – HART 6, FOUNDATION Fieldbus™ H1 or Profibus PA™ H1
Span		15 cm to 610 cm (6" to 240")
Resolution		Analog: 0,01 mA Display: 0,1 (cm or inch)
Loop Resistance		630 Ω @ 20,5 mA - 24 V DC
Damping		Adjustable 0-10 s
Diagnostic Alarm		Adjustable 3,6 mA, 22 mA, HOLD last output
User Interface		HART® communicator, AMS® or PACTware™, FOUNDATION Fieldbus™, Profibus PA™ and/or 3-button keypad
Display		2-line x 8-character LCD
Menu Language		English/Spanish/French/German (FOUNDATION Fieldbus™, Profibus PA™: English)
Housing Material		304 stainless steel, IP 67
Approvals		ATEX II 1 G Ex ia IIC T4 Ga, intrinsically safe FOUNDATION Fieldbus™ and Profibus PA™ units are ATEX FISCO (intrinsically safe) EHEDG (per TNO) and 3A certification Other approvals are available, consult factory for more details
SIL ^① (Safety Integrity Level)	Standard electronics	Functional safety to SIL 1 as 1oo1 / SIL 2 as 1oo2 in accordance to IEC 61508 – SFF of 84,5 %
	Enhanced electronics	Functional safety to SIL 2 as 1oo1 in accordance to IEC 61508 – SFF of 91 % Certified for use in SIL 3 loops
Electrical Data		U _i = 28,4 V, I _i = 124 mA, P _i = 0,84 W (HART®) U _i = 17,5 V, I _i = 380 mA, P _i = 5,32 W (FOUNDATION Fieldbus™ / Profibus PA™)
Equivalent Data		C _i = 3 nF, L _i = 3 μH
Shock/Vibration Class		ANSI/ISA-S71.03 Class SA1 (Shock), ANSI/ISA-S71.03 Class VC2 (Vibration)
Surge protection		Meets CE EN 61326 (1000V)
Net weight		1,4 kg (3.1 lbs) – transmitter head / electronics only
FOUNDATION Fieldbus™ specifications	ITK Version	5.0
	H1 Device Class	Link Master (LAS) – selectable ON/OFF
	Function Blocks	1 x RB, 4 x AI, 1 x TB and 1 x PID
	Execution time	AI = 15 ms, PID = 40 ms
	Quiescent current draw	15 mA
	DD/CFF files	Available at www.fieldbus.org
Profibus PA specifications	Device revision	0x01
	Digital communication protocols	Version 3.0 MBP (31.25 kbits/sec)
	Function Blocks	1 x PB, 4 x AI blocks, 1 x TB
	Execution time	15 ms
	Quiescent current draw	15 mA
	GSD files	Available at www.profibus.com

① Not applicable for FOUNDATION Fieldbus™ and Profibus PA™ units.

PERFORMANCE

Description		Specification
Reference conditions		Reflection from water at +20 °C (+70 °F) with 1,8 m (72") single rod probe in metal vessel (CFD threshold)
Linearity	water based liquid	< 0,1 % of probe length or 1,0 mm (0.05"), whichever is greater
	oil based liquid	< 0,3 % of probe length or 8 mm (0.3"), whichever is greater
Accuracy	water based liquid	< 0,1 % of probe length or 2,5 mm (0.1"), whichever is greater
	oil based liquid	± 0,5 % of probe length or 13 mm (0.5"), whichever is greater
Resolution		± 1,0 mm (0.1")
Repeatability		< 2,5 mm (0.1") (± 0,025 % of volume when using strapping table)
Hysteresis		< 2,5 mm (0.1")
Response Time		< 1 second
Warm-up Time		< 5 seconds
Ambient Temp.		-40 °C to +80 °C (-40 °F to +175 °F) – blind transmitter -20 °C to +70 °C (-5 °F to +160 °F) – with digital display -40 °C to +70 °C (-40 °F to +160 °F) – for Ex ia with blind transmitter -20 °C to +70 °C (-5 °F to +160 °F) – for Ex ia with digital display
Process Dielectric Effect		< 7,5 mm (0.3") within selected range
Operating Temp. Effect		Approx. +0,02 % of probe length/°C for probes ≥ 2,5 m (8')
Humidity		0-99 %, non-condensing
Electromagnetic Compatibility		Meets CE requirements (EN 61326: 1997 + A1 + A2) and NAMUR NE 21 (must be used in metallic vessel or stillwell)

PROBE SPECIFICATIONS

Description		GWR probe specifications
Materials	Probe	316/316L (1.4401/1.4404), Hastelloy® C22 (2.4602) or AL-6XN stainless steel (UNS N08367); 7MH also available in 316L (1.4435) stainless steel
	Process seal	7MF: PTFE (GRAS 21CFR177-1550 and USP <88> Class VI at 121 °C) 7MH: PEEK & 'O'-ring in Viton or EPDM (GRAS 21CFR177-1550 and USP <88> Class VI at 121 °C)
Probe diameter		13 mm (0.50") or 6 mm (0.25")
Mounting		See mounting considerations on page 4
Probe length		From 30 cm to 610 cm (12" to 240") (selectable per 1 cm)
Blocking distance (top)		0 mm up to 910 mm (0" up to 36") - depending probe length (adjustable)
Transition Zone ^① (bottom)		εr ≥ 10: 25 mm (1")
Process Temp.	Max	+150 °C @ 13,8 bar (+300 °F @ 200 psi) for 7MH with Viton GF 'O'-rings and 7MF +120 °C @ 13,8 bar (+250 °F @ 200 psi) for 7MH with EPDM 'O'-rings
	Min	-40 °C @ 13,8 bar (-40 °F @ 200 psi)
Max Process Pressure		13,8 bar @ +150 °C (200 psi @ +300 °F) for 7MH with Viton GF 'O'-rings and 7MF 13,8 bar @ +120 °C (200 psi @ +250 °F) for 7MH with EPDM 'O'-rings
Max Viscosity		10.000 mPa.s (cP) – consult factory in case of agitation/turbulence
Dielectric Range		εr 10-100 (depending installation conditions, down to εr ≥ 1,9) – liquids
Media coating		Max error of 10 % of coated length. % Error is related to dielectric of medium, thickness of coating and coated probe length above level.

^① Transition Zone is dielectric dependent; εr = dielectric permittivity. It is recommended to set 4-20 mA signal outside the transition zones whenever possible.

TEMPERATURE-PRESSURE RATING FOR ECLIPSE PROBE SEALS

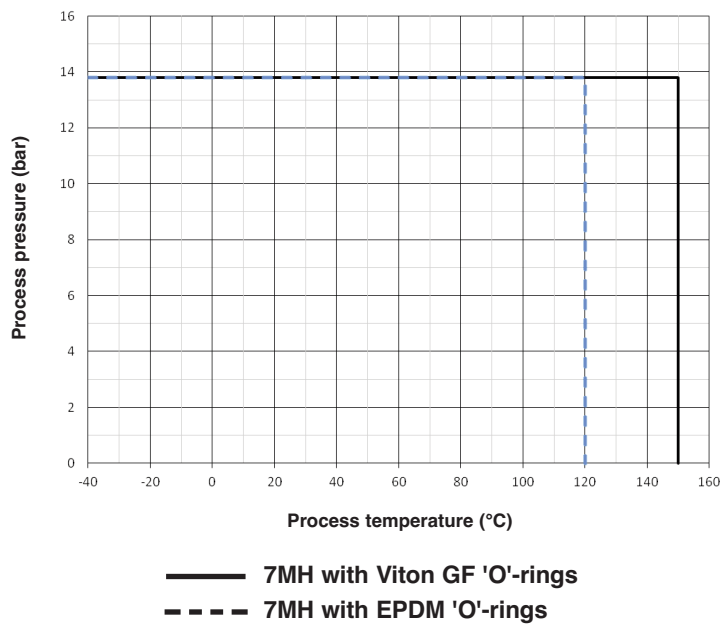
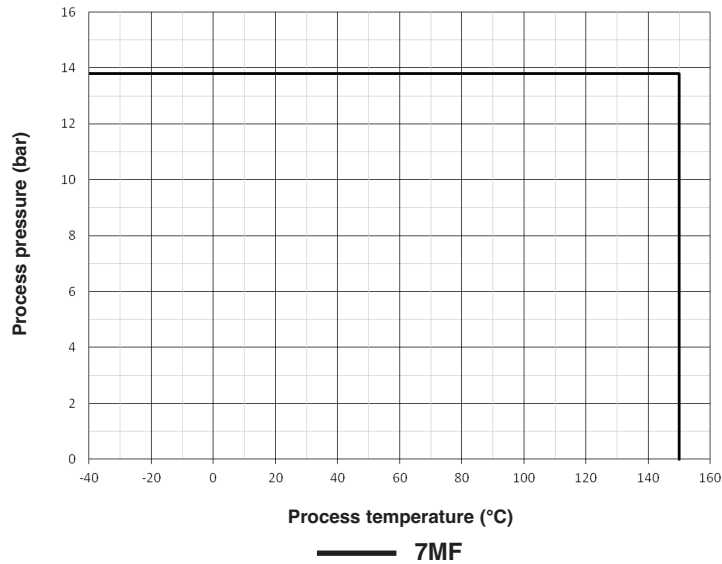

QUALITY ASSURANCE - ISO 9001

THE QUALITY ASSURANCE SYSTEM IN PLACE AT MAGNETROL GUARANTEES THE HIGHEST LEVEL OF QUALITY DURING THE DESIGN, THE CONSTRUCTION AND THE SERVICE OF CONTROLS. OUR QUALITY ASSURANCE SYSTEM IS APPROVED AND CERTIFIED TO ISO 9001 AND OUR TOTAL COMPANY IS COMMITTED TO PROVIDING FULL CUSTOMER SATISFACTION BOTH IN QUALITY PRODUCTS AND QUALITY SERVICE.

PRODUCT WARRANTY

ALL MAGNETROL ELECTRONIC AND ULTRASONIC LEVEL CONTROLS ARE WARRANTED FREE OF DEFECTS IN MATERIALS AND WORKMANSHIP FOR 18 MONTHS FROM THE DATE OF ORIGINAL FACTORY SHIPMENT. IF RETURNED WITHIN THE WARRANTY PERIOD; AND, UPON FACTORY INSPECTION OF THE CONTROL, THE CAUSE OF THE CLAIM IS DETERMINED TO BE COVERED UNDER THE WARRANTY; THEN, MAGNETROL INTERNATIONAL WILL REPAIR OR REPLACE THE CONTROL AT NO COST TO THE PURCHASER (OR OWNER) OTHER THAN TRANSPORTATION. MAGNETROL SHALL NOT BE LIABLE FOR MISAPPLICATION, LABOR CLAIMS, DIRECT OR CONSEQUENTIAL DAMAGE OR EXPENSE ARISING FROM THE INSTALLATION OR USE OF THE EQUIPMENT. THERE ARE NO OTHER WARRANTIES EXPRESSED OR IMPLIED, EXCEPT, SPECIAL WRITTEN WARRANTIES COVERING SOME MAGNETROL PRODUCTS.

BULLETIN N°: BE 57-110.6
 EFFECTIVE: AUGUST 2021
 SUPERSEDES: February 2020

UNDER RESERVE OF MODIFICATIONS

European Headquarters & Manufacturing Facility

Heikensstraat 6
 9240 Zele, Belgium
 Tel: +32-(0)52-45.11.11
 e-mail: info@magnetrol.be

www.magnetrol.com



MAGNETROL®

AMETEK®
 SENSORS, TEST & CALIBRATION