

ZIMMERLI MESSTECHNIK AG

Pressure Relief Valve, springloaded

for steam, gases and liquids

Typ 81

Technical documentation



DN 10 - DN 100

Contents

- **Technical Data**

- Datasheet
- Spring ranges
- Datasheet position

- **Assembly, care and maintenance**

- Mounting Instructions
- Storage, transport and commissioning
- Maintenance Instructions
- Troubleshooting operating problems

General Take-back conditions



2

Attention!



ZIMMERLI MESSTECHNIK AG reserves the right to decide on taking back its products on an application-dependent basis.

Basically, only such products will be taken back, as remain unused and are not older than two years (date of delivery).

The costs of the assembly services rendered as well as expenses incurred in connection with the take-back will be deducted.

Custom-made products will basically, not be taken back.

In cases of custom-made products, order cancellations after the start of production shall not be free-of-charge. Production expenses that have already been incurred shall be invoiced on the basis of the status of production.

Spare parts and wearing parts shall be excluded from these conditions and will generally not be taken back irrespective of the condition they are in.

Pressure Relief Valve, springloaded

for steam, gases and liquids

Typ 81

Standard version:

Material: Valve-body / media contact surfaces

Typ 81.2: BG 0 - II 1.4301, 1.4571 / 1.4571
BG III - IV 1.4571 / 1.4571

Connections:

Flange connections: DIN EN / ASME B16.5

Sealings:

FPM, EPDM
 PTFE, EPDM (steam up to 150°C)
 PTFE, FEPM, EPDM (steam up to 200°C)

Approvals:

Pressure Equipment Directive: 2014/68/EU
 Declaration of Conformity

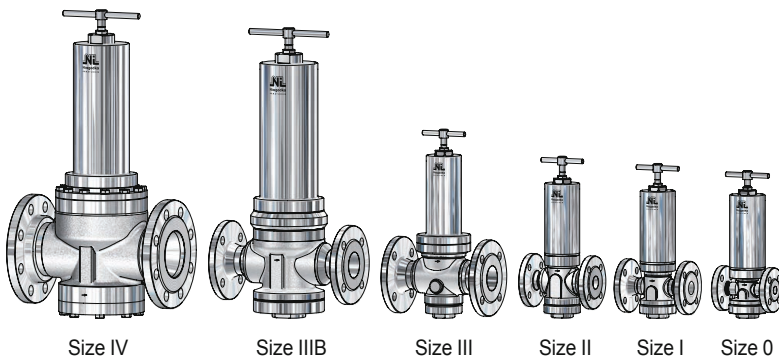
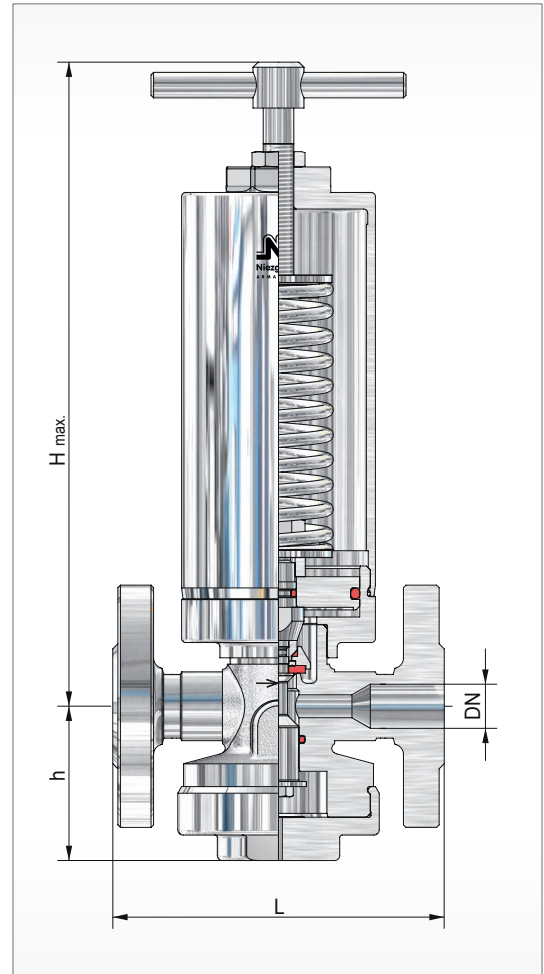

Size	Inlet			Outlet		Dimensions				Kvs value [m³/h]		
	DN	NPS	PN		DN	NPS	Height 'H' max.					
			min.	max.			Toggle spindle [mm]	Cap [mm]	L [mm]		h [mm]	
0	10	-	0,35 / 104,00		10	-	275	265	130	59	2,0	
	15	1/2			15	1/2					2,2	
I	15	1/2	0,35 / 59,00		15	1/2	305	270	130	67	3,0	
	20	3/4			20	3/4					3,2	
	25*	1*			25*	1*					160	3,5
II	25	1	0,25 / 25,00		25	1	315	275	160	75	6,3	
	32	1 1/4			32	1 1/4					180	6,5
	40*	1 1/2*			40*	1 1/2*					200	6,7
III	40	1 1/2	0,25 / 17,00		40	1 1/2	360	325	200	90	12,5	
	50	2			50	2					230	13,0
	65*	2 1/2*			65*	2 1/2*					290	13,5
IIIB	50	2	0,25 / 12,00		50	2	570	535	300	112	27,5	
	65	2 1/2			65	2 1/2					290	28,0
	80	3			80	3					310	28,5
IV	65	2 1/2	0,20 / 13,20		65	2 1/2	600	565	290	140	48,0	
	80	3			80	3					310	50,0
	100	4			100	4					350	53,0

other design on request

* special size

Pressure Relief Valve, springloaded

for steam, gases and liquids

Typ 81

Spring ranges for initial pressure P₁

Piston plate [mm]	Ø 139	Ø 119	Ø 99	Ø 84	Ø 64	Ø 48	Ø 38	Ø 27
Size	Spring no.	[bar(g)]						
0	303				0,35 - 0,70			
	304				0,71 - 1,20			
	305				1,30 - 2,00			
	306				2,10 - 3,00	4,60 - 6,00	9,10 - 10,00	15,10 - 26,00
	307				3,10 - 4,50	6,10 - 9,00	10,10 - 15,00	26,10 - 39,00
	308							39,10 - 48,00
	309							48,10 - 62,00
	310							62,10 - 85,00
	311							85,10 - 104,00
I	303				0,35 - 0,70			
	304				0,71 - 1,00			
	305				1,10 - 2,00			
	306				2,10 - 3,00	4,60 - 6,00	8,60 - 10,00	15,10 - 25,00
	307				3,10 - 4,50	6,10 - 8,50	10,10 - 15,00	25,10 - 38,00
	308							38,10 - 46,00
	309							46,10 - 59,00
II	303				0,25 - 0,40			
	304				0,41 - 0,70			
	305				0,71 - 1,00			
	306				1,10 - 1,60	2,60 - 3,00	4,60 - 7,00	10,10 - 14,00
	307				1,70 - 2,50	3,10 - 4,50	7,10 - 10,00	14,10 - 21,00
	308							21,10 - 25,00
III	323			0,25 - 0,40				
	324			0,41 - 0,70				
	325			0,71 - 1,00	1,10 - 1,50	2,60 - 3,50	6,60 - 11,00	
	326				1,60 - 2,50	3,60 - 5,50	11,10 - 17,00	
	327					5,60 - 6,50		
IIIB	353		0,25 - 0,50					
	354		0,51 - 0,90					
	355		1,00 - 1,30					
	356		1,40 - 2,00	2,10 - 3,00				
	357			3,10 - 5,50	5,60 - 9,00			
	358				9,10 - 12,00			
IV	353	0,20 - 0,43						
	354	0,44 - 0,70						
	355	0,71 - 1,00						
	356	1,10 - 1,50		2,60 - 4,10				
	357	1,60 - 2,50		4,20 - 6,80	6,90 - 13,20			

Pressure Relief Valve, springloaded

for steam, gases and liquids

Typ 81

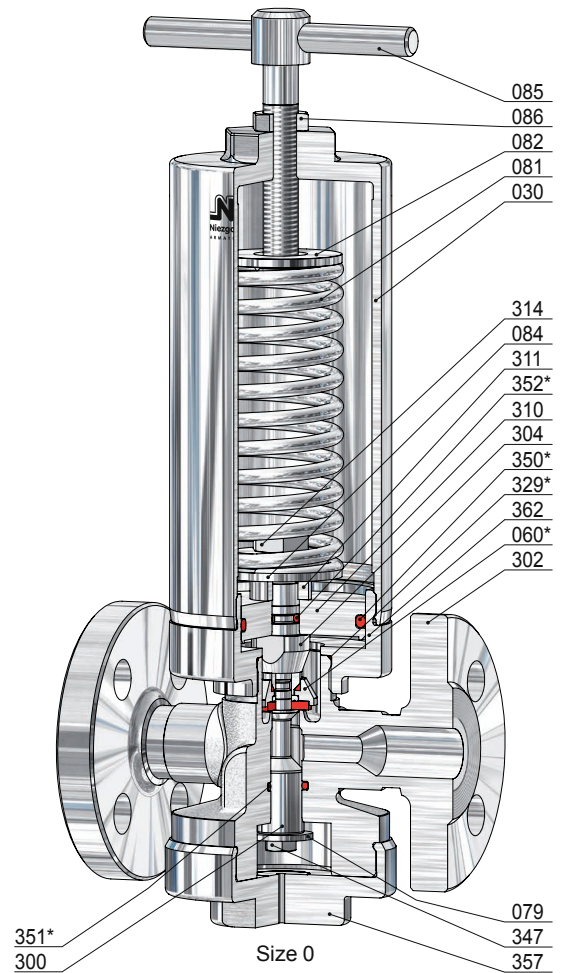
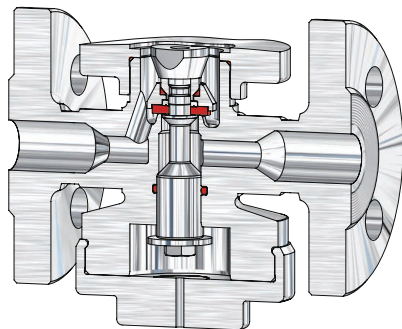
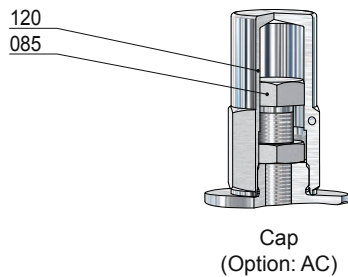

Item	Piece	Description	Item	Piece	Description
302	1	valve body	120	1	cap
030	1	spring bonnet	300	1	piston
060 *	1	disc, complete	304	1	inlet pressure piston
560	1	disc	310	1	piston plate
061	1	pressure piece	311	1	distance bush
062	1	soft sealing	314	1	lock nut
071	1	o-ring	329 *	1	o-ring
072	1	locking ring	347	1	screw
073	1	o-ring (only for thermoplastics soft sealing)	350 *	1	o-ring
079	1	lift stopper	351 *	1	o-ring
081	1	spring	352 *	1	o-ring
082	1	springplate, upper	357	1	bottom plug
084	1	springplate, lower	362	1	adapter
085	1	adjusting screw			
086	1	lock nut			

* expendable parts

Pressure Relief Valve, springloaded

for steam, gases and liquids

Typ 81

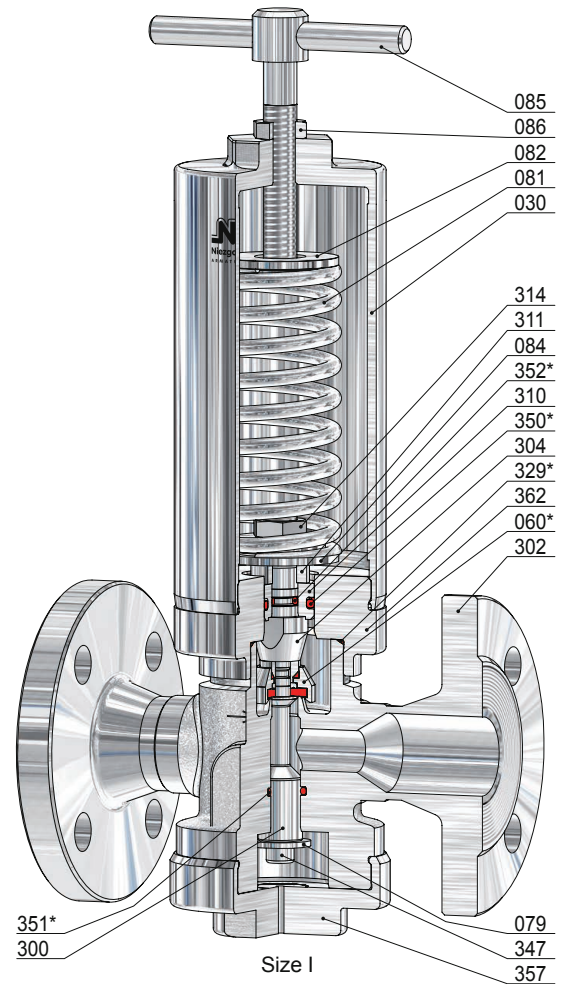
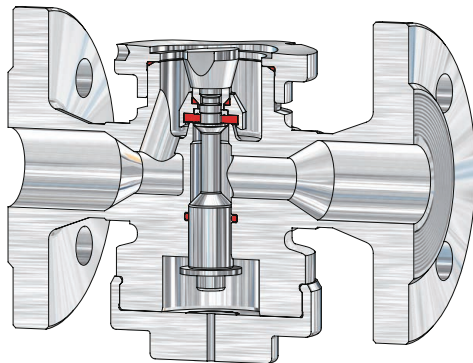
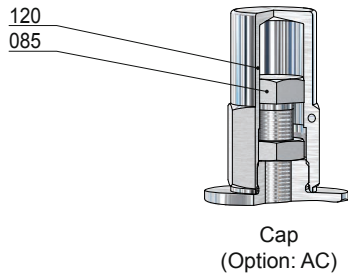

Item	Piece	Description	Item	Piece	Description
302	1	valve body	120	1	cap
030	1	spring bonnet	300	1	piston
060 *	1	disc, complete	304	1	inlet pressure piston
560	1	disc	310	1	piston plate
061	1	pressure piece	311	1	distance bush
062	1	soft sealing	314	1	lock nut
071	1	o-ring	329 *	1	o-ring
072	1	locking ring	347	1	screw
073	1	o-ring (only for thermoplastics soft sealing)	350 *	1	o-ring
079	1	lift stopper	351 *	1	o-ring
081	1	spring	352 *	1	o-ring
082	1	springplate, upper	357	1	bottom plug
084	1	springplate, lower	362	1	adapter
085	1	adjusting screw			
086	1	lock nut			

* expendable parts

Pressure Relief Valve, springloaded

for steam, gases and liquids

Typ 81

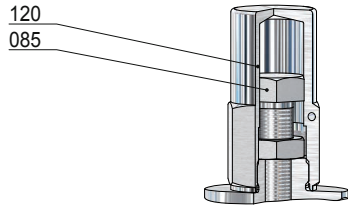

Cap
(Option: AC)

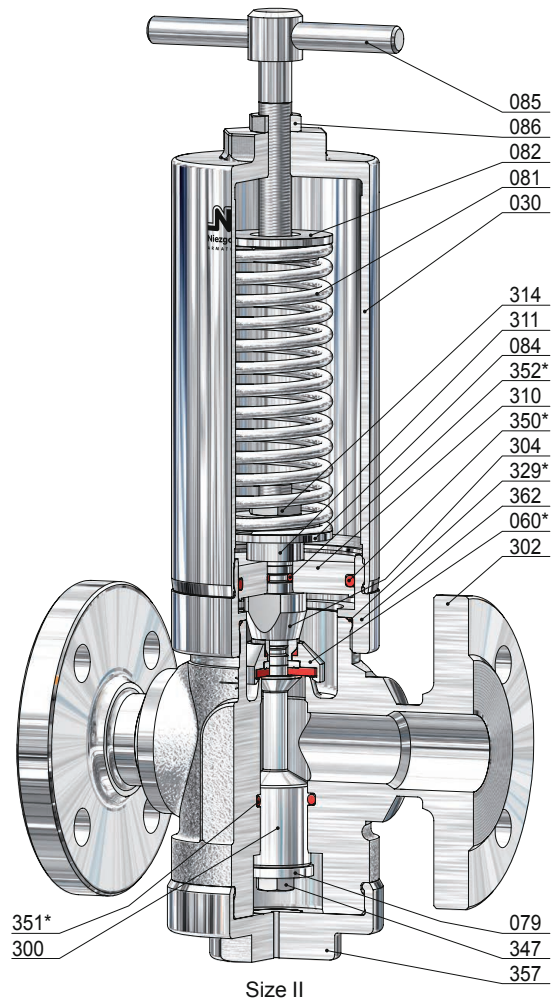
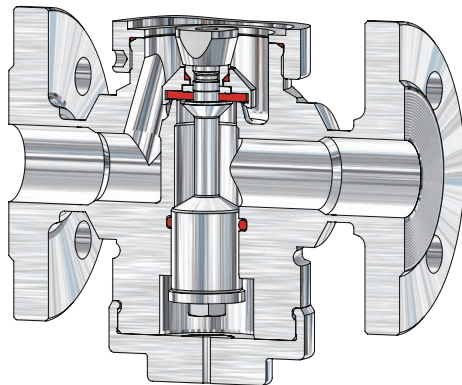

Size II

Item	Piece	Description	Item	Piece	Description
302	1	valve body	120	1	cap
030	1	spring bonnet	300	1	piston
060 *	1	disc, complete	304	1	inlet pressure piston
560	1	disc	310	1	piston plate
061	1	pressure piece	311	1	distance bush
062	1	soft sealing	314	1	lock nut
071	1	o-ring	329 *	1	o-ring
072	1	locking ring	347	1	screw
073	1	o-ring <i>(only for thermoplastics soft sealing)</i>	350 *	1	o-ring
079	1	lift stopper	351 *	1	o-ring
081	1	spring	352 *	1	o-ring
082	1	springplate, upper	357	1	bottom plug
084	1	springplate, lower	362	1	adapter
085	1	adjusting screw			
086	1	lock nut			

* expendable parts

Pressure Relief Valve, springloaded

for steam, gases and liquids

Typ 81

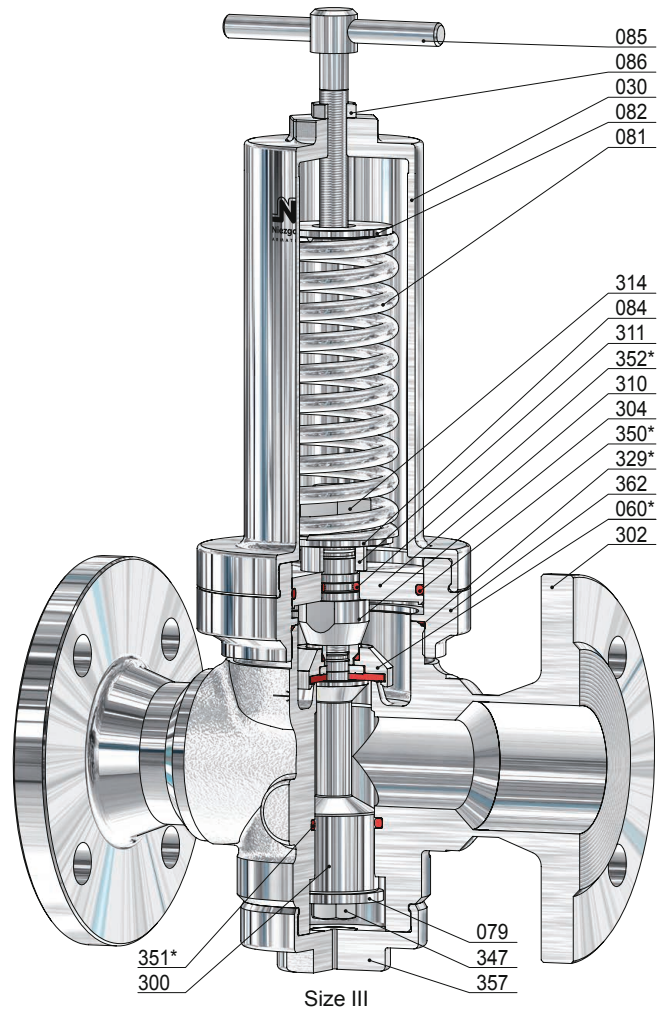
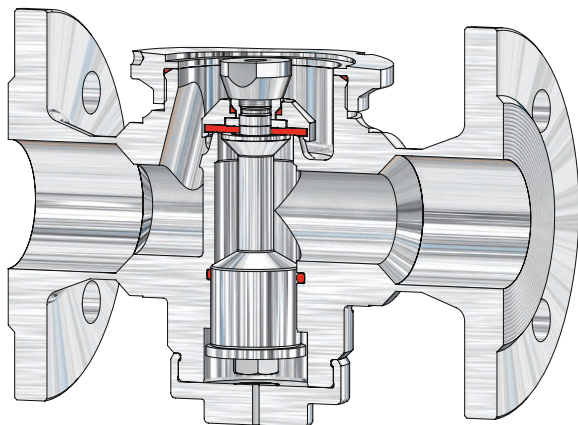
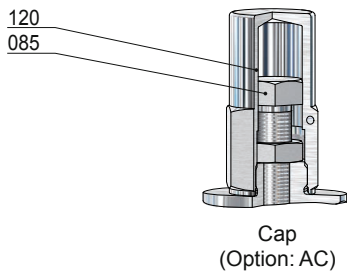

Item	Piece	Description	Item	Piece	Description
302	1	valve body	120	1	cap
030	1	spring bonnet	300	1	piston
060 *	1	disc, complete	304	1	inlet pressure piston
560	1	disc	310	1	piston plate
061	1	pressure piece	311	1	distance bush
062	1	soft sealing	314	1	lock nut
071	1	o-ring	329 *	1	o-ring
072	1	locking ring	347	1	screw
073	1	o-ring <i>(only for thermoplastics soft sealing)</i>	350 *	1	o-ring
079	1	lift stopper	351 *	1	o-ring
081	1	spring	352 *	1	o-ring
082	1	springplate, upper	357	1	bottom plug
084	1	springplate, lower	362	1	adapter
085	1	adjusting screw			
086	1	lock nut			

* expendable parts

Pressure Relief Valve, springloaded

for steam, gases and liquids

Typ 81

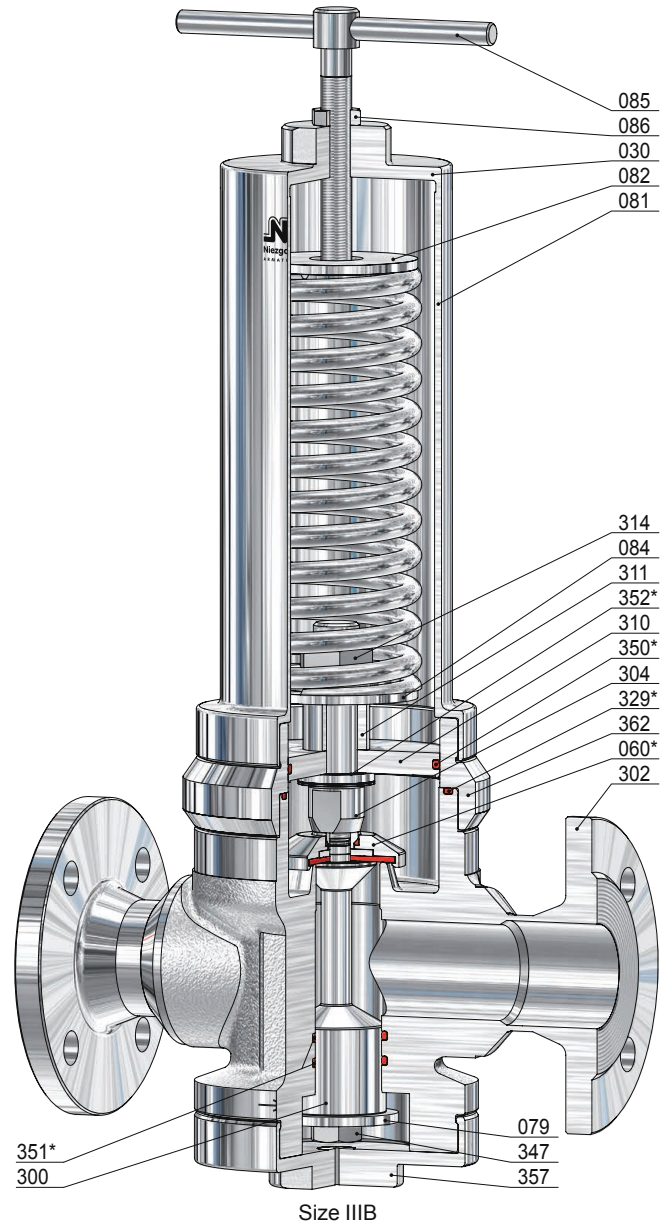
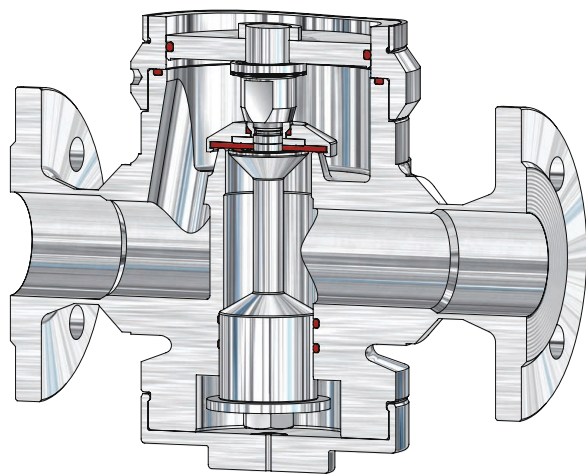
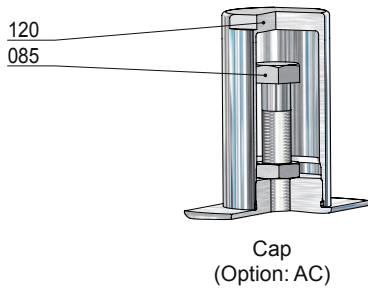

Item	Piece	Description	Item	Piece	Description
302	1	valve body	120	1	cap
030	1	spring bonnet	300	1	piston
060 *	1	disc, complete	304	1	inlet pressure piston
560	1	disc	310	1	piston plate
061	1	pressure piece	311	1	distance bush
062	1	soft sealing	314	2	lock nut
071	1	o-ring	329 *	1	o-ring
072	1	locking ring	347	1	screw
073	1	o-ring (only for thermoplastics soft sealing)	350 *	1	o-ring
079	1	lift stopper	351 *	2	o-ring
081	1	spring	352 *	1	o-ring
082	1	springplate, upper	357	1	bottom plug
084	1	springplate, lower	362	1	adapter
085	1	adjusting screw			
086	1	lock nut			

* expendable parts

Pressure Relief Valve, springloaded

for steam, gases and liquids

Typ 81

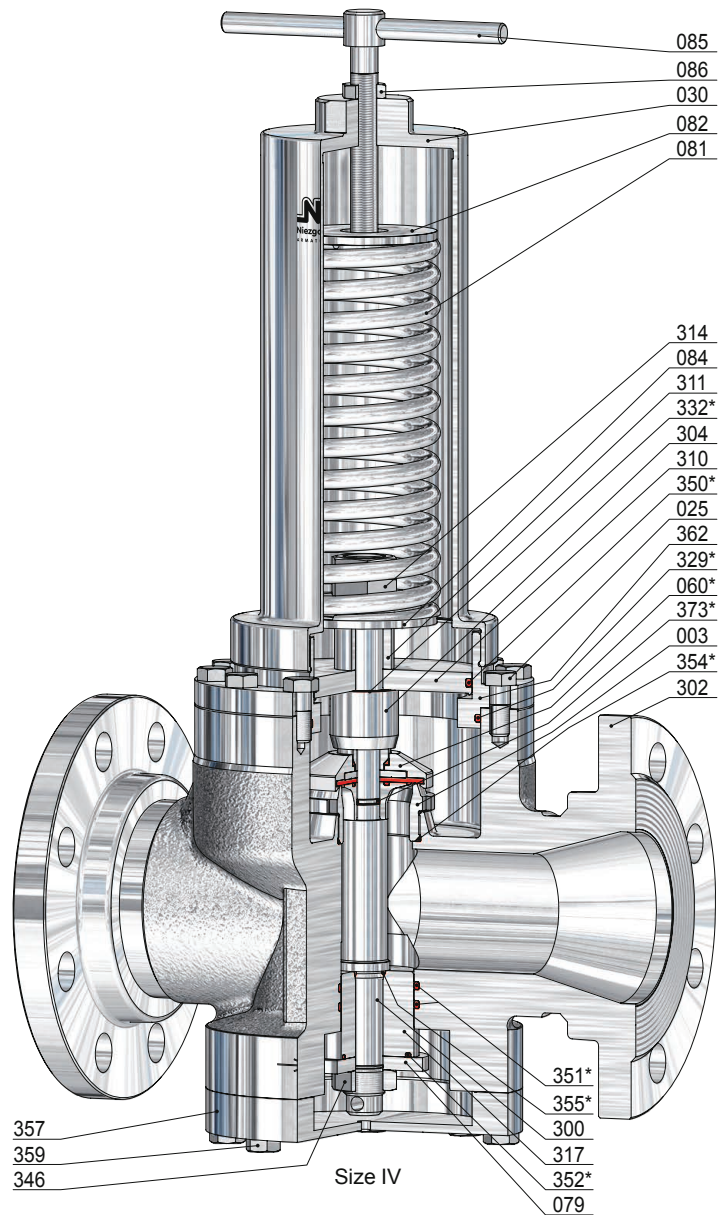
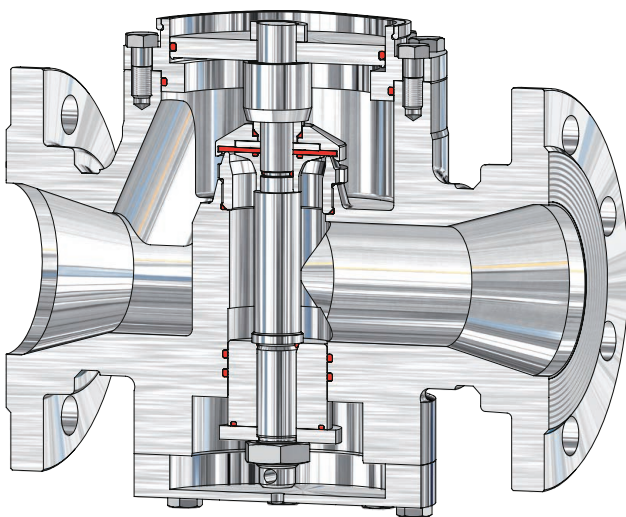
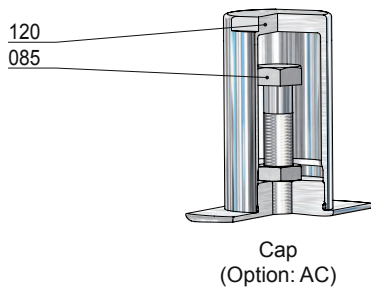

Item	Piece	Description	Item	Piece	Description	Item	Piece	Description
302	1	valve body	081	1	spring	332 *	1	o-ring
003	1	seat	082	1	springplate, upper	346	1	nut
025	12	screw	084	1	springplate, lower	350 *	1	o-ring
030	1	spring bonnet	085	1	adjusting screw	351 *	2	o-ring
060 *	1	disc, complete	086	1	lock nut	352 *	1	o-ring
560	1	disc	120	1	cap	354 *	1	o-ring
061	1	pressure piece	300	1	piston	355 *	1	o-ring
062	1	soft sealing	304	1	inlet pressure piston	357	1	bottom plug
071	1	o-ring	310	1	piston plate	359	8	screw
072	1	locking ring	311	1	distance bush	362	1	adapter
073	1	o-ring	314	2	lock nut	373 *	1	o-ring
074	1	disc plate	317	1	piston guide			
079	1	lift stopper	329 *	1	o-ring			

* expendable parts

Installation and operating instructions



15

Initial-Pressure-Controller-Valve

1. Installation

Initial pressure controller valves are preferably to be installed at places in pipeline systems with smooth operation conditions, which means, as a consequence, not directly upstream or downstream of elbows, pipe manifolds, distributors, pressure generators, shut-off valves, isolating valves or other throttling devices. The installation should be carried out in horizontally positioned pipeline systems. The spring hood can, unless stated differently, be installed at the bottom or at the top. In the case of liquids, the spring hood should show in the bottom direction; in the case of steam the spring hood must show in the bottom direction.

The Illustrations 1 - 4 show the most frequent way of installation of an initial pressure controller valve in the pipeline. In installations which are highly important for the operation of the plant and whose breakdown would cause an unacceptable stoppage of the plant, a stop-and-check bypass duct (Illustration 5 - 6) can be installed. In the case of a breakdown, an emergency operation can be maintained by means of the bypass. Under normal operation conditions, the bypass is to be held closed.

Prior to the installation of the initial pressure controller valve, the pipeline must be cleaned and rinsed carefully. A sediment separator in the form of a dirt catcher (4) is to be provided if a contamination cannot be prevented during operation. After the removal of the packaging material, including plastic closing caps, the installation of the initial pressure controller valve is to be carried out in the pipeline, while the flow direction (arrow) indicated must be observed.

Initial pressure controller valves do not, as regulating valves, represent any sort of check valves which warrant a tight seat. According to VDI/VDE Guideline 2174, a leakage of 0.05 % of the Kvs value is permissible. We recommend, therefore, the installation of an upstream shut-off valve (1).

2. Safety Devices

Initial pressure controller valves are no substitute for safety installations.

The pipeline or installation inserted upstream of the initial pressure controller valve must, for this reason, be secured by means of a safety device, for instance by means of a safety valve (6). The safety valve must be designed with dimensions sufficiently large. The response pressure of the safety valve should be set approximately 40 percent above the maximum setting pressure of the initial pressure controller valves so that a blowing off at slight pressure fluctuations is avoided. Furthermore, the operator must also safeguard that the medium that is released in case the control piston seal or diaphragm is damaged from the spring hood does not represent an environmental risk. If necessary, a leakage pipeline must be connected at the spring hood.

3. Operation

Before leaving the factory, the pressure controller valve has been checked for leaks. With steam, it will be necessary to tighten the screws and the bottom plug (357) the pressure controller valve has thoroughly heated up.

Before putting the valve into operation, the spring (081) should be released (by turning the adjusting screw (085) anticlockwise).

Initially, the downstream checking valve (2) must be opened, and subsequently the upstream checking valve (1) can be opened.

Next, the upstream pressure or excess flowing pressure value is to be set to the desired pressure value. For this purpose, the adjusting screw (085) is to be rotated in the clockwise direction until the upstream pressure value is reached. In this connection, the upstream manometer (7) must be observed. Once the adjustment is complete, the adjusting screw (085) should be secured with the lock nut (086).

A sharply fluctuating flow or shock pressure loading are to be avoided.



Piston design

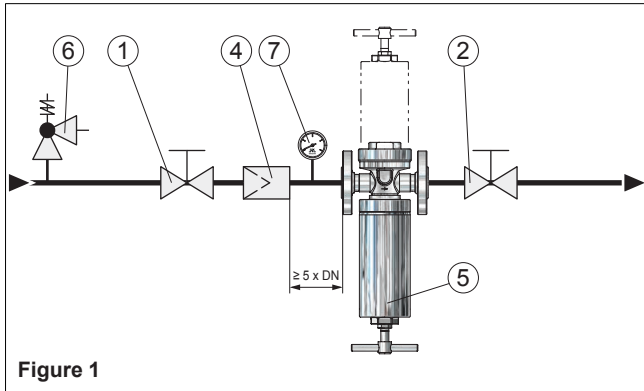

Figure 1

Diahragm design

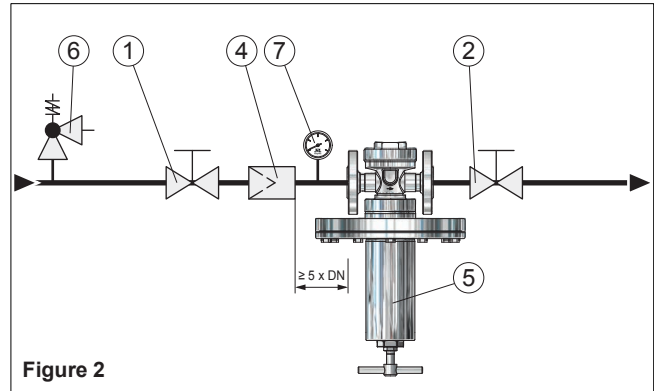

Figure 2

Initial pressure controller valve without bypass pipeline

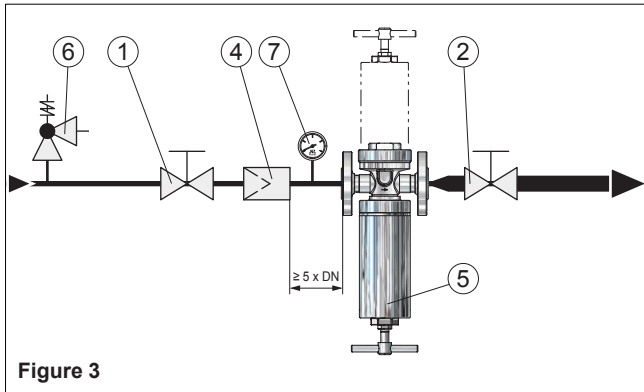

Figure 3

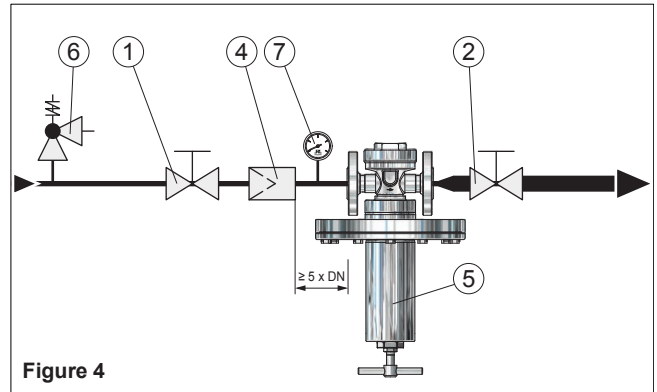

Figure 4

Initial pressure controller valve without bypass pipeline with pipe downstream enlargement at the outlet

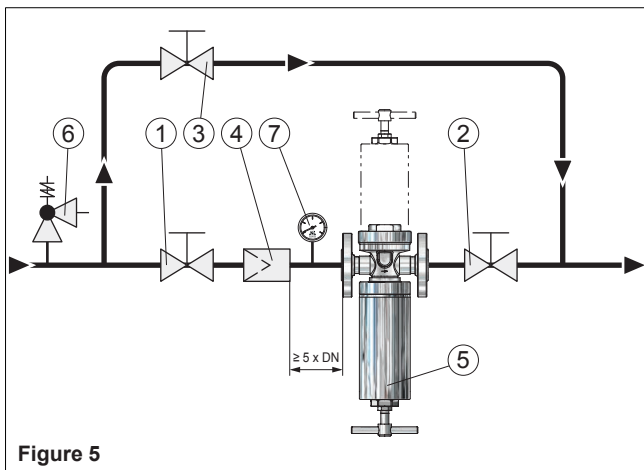

Figure 5

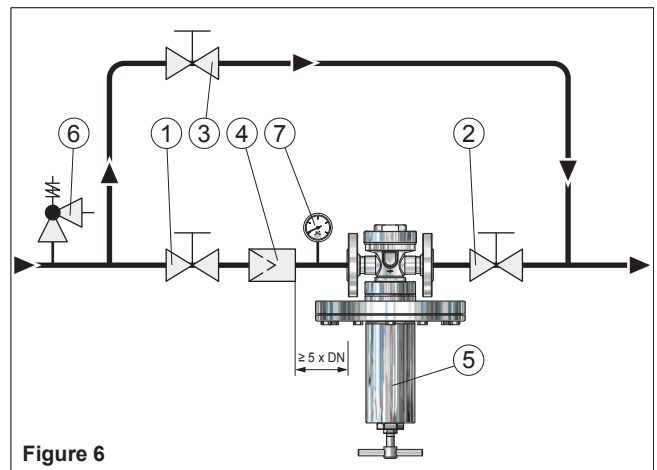

Figure 6

Initial pressure controller valve with bypass pipeline

The installation of an initial pressure controller valve is in the case of gases in a standing position, in the case of liquids preferably in a suspended position, in the case of steam only in a suspended position.

Item	Description	Item	Description	Item	Description
1	Shut-off valve	4	Strainer	7	Pressure gauge
2	Shut-off valve	5	Initial pressure controller valve		
3	Shut-off valve	6	Safety valve		



General: **NI-Valves** are high quality products which must be treated with care. The sealing faces on the seating (001 / 003) and disc (060) are hardened, annealed, ground and lapped. Improper handling can cause them to be damaged, resulting in leakage and inoperability. They must therefore be protected against shocks (throwing, impacting, hitting etc.). On valves equipped with a venting lever etc., the lever must not be misused as a carrying handle. All valves are to be properly secured to prevent them falling over or falling down in the course of transportation, fitting and maintenance.

Observe the following storage instructions:

Environment: Places of storage must be clean and dry.

Temperatures: **NI-Valves** should be stored at temperatures between 5°C to 35°C, the best being 10°C to 20°C. The instructions for disc sealing must be complied with in the case of soft sealing valves.

Transportation: Only use suitable packing materials for transportation. Inlet and outlet apertures are to be protected for transportation purposes by caps or plugs which are only to be removed shortly prior to assembly.

Commissioning:

Delayed initial opening caused by so-called sticking (adhesion) effect of the seating (001 / 003) and disc (060) is quite normal after transportation and longer storage of valves with a preset response pressure. This applies both to metal/elastomers sealing faces and highly polished metal/metal faces.

When the valve has been fitted the sealing faces are separated by pressurisation higher than the actual response pressure and by operating the venting lever.

The valve, together with the preset pressure response, is now fully functional, taking the permissible pressure increase/closing pressure into consideration.

Attention!



- The regional safety regulations are to be observed.
- The material, pressure, temperature and flow direction specifications must be checked prior to commissioning.
- The valve data are to be checked for position (arrangement) in the system.
- Residues in pipelines and valves (welding beads, grinding dust, dirt etc.) lead to leakage or damage.
- Touching the valve can give rise to the risk of injury when it is operated at high medium temperatures of (>50°C) or low temperatures of (>0°C).
- Remove the blocking screw (149), which may have been used, from the cap (120).
- Remove protective caps and lever fixtures prior to commissioning.
- Sticking, freezing or blockage of the valve is to be avoided without fail.
- When a blow-out pipe is not used, the medium can suddenly escape from the valve outlet aperture. **Hazard!**
- Large amounts of flow noise can be heard when blowing out.

Care is to be taken to ensure prior to putting a new system into operation or restarting a system that has been subject to repair or conversion that:

- All work is completed in an orderly manner!
- The valve is in the correct function position.
- Safety devices are in place.

Instructions for maintenance

for Initial-Pressure-Controller



15

Maintenance:

NI initial pressure controller shall be provided in design and manufacture in such a way that optimal quality and service-friendliness is attained. Minimum care and maintenance is the result when using our fittings.

We recommend to have the initial pressure controller / spare parts replaced only in an authorized technical workshop. In the absence of adequate means of repair, it is advisable to send the device on the ZIMMERLI MESSTECHNIK AG. All spare parts supplied by us are suitable for installation in our valves without exception. Since the valves supplied are however adapted to the respective case of application, it is necessary to also state our **valve number** and the delivery slip / invoice number or order number of processing while placing order for spare parts.

Test intervals:

Depending on the properties of the medium and the operational circumstances in the facility, maintenance shall be performed or function of valve verified once each year or also at shorter intervals.

Leakages:

Faults are often caused by soiling, which result in damages or softening of seals:

Leakages on the piston plate sealing (o-ring 350) are indicated by medium escaping through the spring hood opening. To repair, the respective o-ring (350) shall be renewed. A media stream or increasing pressure in the overflow line with the valve closed indicates a defective plug seal (062) and / or a defective O-ring (351).

Caution!



In case of oxygen, keep all parts free of oil and grease. For operation in oxygen-charged atmosphere (-25°C/+250°C), only approved lubricants, e.g. „ **gleitmo 594** “ shall be used for the lubrication of the o-rings, media-contacting guide areas and thread connections.

Attention!



Care must be taken to ensure that the system is depressurised prior to assembly, dismantling or opening of the initial pressure controller. The remaining dimensions and seal properties, preloading forces, tightening torques etc. are to be determined by the user themselves in accordance with the operating instructions. In doing so special attention must be paid to the following:

Medium residues in the initial pressure controller or in the spring cap represent a serious chemical burning, burns and poisoning hazard. It must, therefore, be established prior to removing a valve from the plant which medium could be present in the initial pressure controller valve. Appropriate safety measures must be taken.

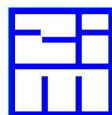

ZIMMERLI MESSTECHNIK AG

Schlossgasse 10 Postfach 7 CH-4125 Riehen Telefon +41 61-645 98 00 Fax +41 61-645 98 01
www.zimmerliag.com www.zimmerli-inert.com info@zimmerliag.com



For further information, see our website