

General Specifications

Model EJA110A Differential Pressure Transmitter

DPherp

GS 01C21B01-00E

The high performance differential pressure transmitter model EJA110A can be used to measure liquid, gas, or steam flow as well as liquid level, density and pressure. It outputs a 4 to 20 mA DC signal corresponding to the measured differential pressure. Model EJA110A also features remote setup and monitoring through communications with the BRAIN™ terminal and CENTUM CS™ or μXL™ or HART® 275 host.

STANDARD SPECIFICATIONS

Refer to GS 01C22T02-00E for Fieldbus communication type marked with “◇.”

PERFORMANCE SPECIFICATIONS

Zero-based calibrated span, linear output, wetted parts material code ‘S’ and silicone oil.

Reference Accuracy of Calibrated Span

(including the effects of zero-based linearity, hysteresis, and repeatability)

±0.075 % of Span

For spans below X

$$\pm[0.025 + 0.05 \frac{X}{\text{Span}}] \% \text{ of Span}$$

where X equals:

Capsule	X kPa {inH ₂ O}
L	3 {12}
M	10 {40}
H	100 {400}
V	1.4 MPa {200 psi}

Square Root Output Accuracy

The square root accuracy is a percent of flow span.

Output	Accuracy
50 % or Greater	same as reference accuracy
50 % to Dropout point	reference accuracy × 50 square root output (%)

T00E.EPS

Ambient Temperature Effects

Total Effects per 28 °C (50 °F) Change

Capsule	Effect
L	±[0.08 % Span + 0.09 % URL]
M	±[0.07 % Span + 0.02 % URL]
H	±[0.07 % Span + 0.015 % URL]
V	±[0.07 % Span + 0.03 % URL]

Static Pressure Effects

Total Effects per Change

L capsule

±[0.07 % Span+0.052 % URL] per 3.4 MPa {500 psi}

M, H and V capsules

±[0.1% Span+0.028 % URL] per 6.9 MPa {1000 psi}

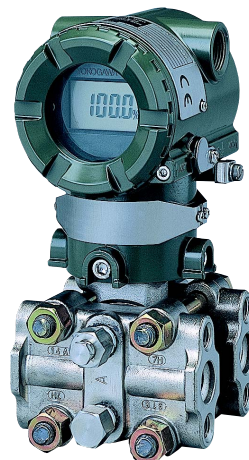

Effect on Zero (can be corrected at line pressure)

L capsule

±[0.02 % Span+0.052 % URL] per 3.4 MPa {500 psi}

M, H and V capsules

±0.028 % of URL per 6.9 MPa {1000 psi}

Overpressure Effects (M, H and V capsules)

±0.03 % of URL per 16 MPa {2300 psi}

Stability (M, H and V capsules)

±0.1 % of URL per 60 months

Power Supply Effects “◇”

±0.005 % per Volt (from 21.6 to 32 V DC, 350 Ω)

FUNCTIONAL SPECIFICATIONS

Span & Range Limits

Measurement Span/Range	kPa	inH ₂ O/(D1)	mbar/(D3)	mmH ₂ O/(D4)
L	Span 0.5 to 10	2 to 40	5 to 100	50 to 1000
	Range -10 to 10	-40 to 40	-100 to 100	-1000 to 1000
M	Span 1 to 100	4 to 400	10 to 1000	100 to 10000
	Range -100 to 100	-400 to 400	-1000 to 1000	-10000 to 10000
H	Span 5 to 500	20 to 2000	50 to 5000	0.05 to 5 kgf/cm ²
	Range -500 to 500	-2000 to 2000	-5000 to 5000	-5 to 5 kgf/cm ²
V*1	Span 0.14 to 14 MPa	20 to 2000 psi	1.4 to 140 bar	1.4 to 140 kgf/cm ²
	Range -0.5 to 14 MPa	-71 to 2000 psi	-5 to 140 bar	-5 to 140 kgf/cm ²

T01E.EPS

*1: For Wetted parts material code other than S, the ranges are 0 to 14 MPa, 0 to 2000 psi, 0 to 140 bar, and 0 to 140 kgf/cm².

URL is defined as the Upper Range Limit from the table above.

Zero Adjustment Limits

Zero can be fully elevated or suppressed, within the Lower and Upper Range Limits of the capsule.

External Zero Adjustment “◇”

External zero is continuously adjustable with 0.01 % incremental resolution of span. Span may be adjusted locally using the digital indicator with range switch.

Mounting Position Effect

Rotation in diaphragm plane has no effect. Tilting up to 90 ° will cause zero shift up to 0.4 kPa {1.6 inH₂O} which can be corrected by the zero adjustment.

Output “◇”

Two wire 4 to 20 mA DC output with digital communications, linear or square root programmable. BRAIN or HART FSK protocol are superimposed on the 4 to 20 mA signal.

Failure Alarm

Output status at CPU failure and hardware error;
 Up-scale: 110%, 21.6 mA DC or more(standard)
 Down-scale: -5%, 3.2 mA DC or less
 Note: Applicable for Output signal code D and E

Damping Time Constant (1st order)

The sum of the amplifier and capsule damping time constant must be used for the overall time constant. Amp damping time constant is adjustable from 0.2 to 64 seconds.

Capsule (Silicone Oil)	L	M	H and V
Time Constant (approx. sec)	0.4	0.3	0.3

Ambient Temperature Limits

(approval codes may affect limits)

- 40 to 85 °C (-40 to 185 °F)
- 30 to 80 °C (-22 to 176 °F) with LCD Display

Process Temperature Limits

(approval codes may affect limits)

- 40 to 120 °C (-40 to 248 °F)

Ambient Humidity Limits

- 5 to 100 % RH @ 40 °C (104 °F)

Working Pressure Limits (Silicone Oil)

Maximum Pressure Limit

Capsule	Wetted parts material code	
	H, M, T, A, D, and B	S
L	3.5 MPa {500 psi}	16 MPa {2300 psi}
M, H, and V	16 MPa {2300 psi}	16 MPa {2300 psi}

Minimum Pressure Limit

See graph below

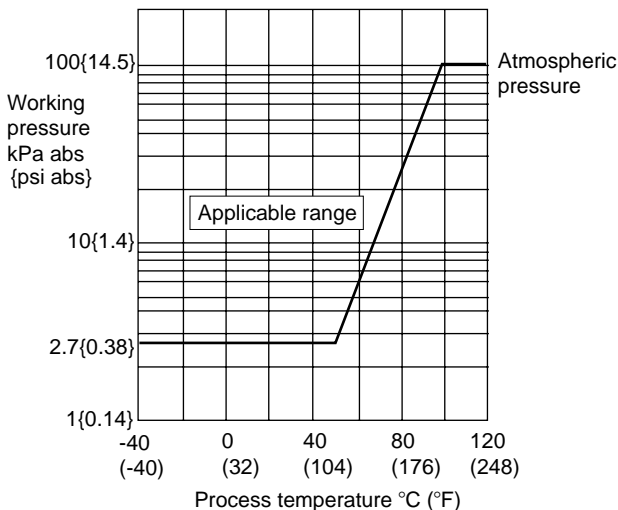

Figure 1. Working Pressure and Process Temperature

Supply & Load Requirements

(Safety approvals may affect electrical requirements)
 With 24 V DC supply, up to a 570 Ω load can be used. See graph below.

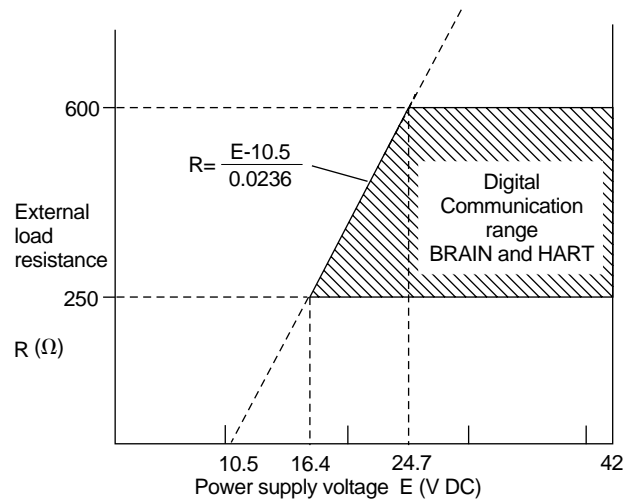

Figure 2. Relationship Between Power Supply Voltage and External Load Resistance

Supply Voltage “◇”

- 10.5 to 42 V DC for general use and flameproof type
- 10.5 to 32 V DC for lightning protector (Optional code /A)
- 10.5 to 30 V DC for intrinsically safe, Type n, nonincendive, or non-sparking type
- Minimum voltage limited at 16.4 V DC for digital communications, BRAIN and HART

Load(Output signal code D and E)

- 0 to 1335 Ω for operation
- 250 to 600 Ω for digital communication

EMC Conformity Standards CE , N200

EN61326, AS/NZS 2064

Communication Requirements “◇”

BRAIN

Communication Distance

Up to 2 km (1.25 miles) when using CEV polyethylene-insulated PVC-sheathed cables. Communication distance varies depending on type of cable used.

Load Capacitance

0.22 μF or less (see note)

Load Inductance

3.3 mH or less (see note)

Input Impedance of communicating device

10 kΩ or more at 2.4 kHz.

Note : For general-use and Flameproof type.
 For Intrinsically safe type, please refer to 'OPTIONAL SPECIFICATIONS.'

HART

Communication Distance

Up to 1.5 km (1 mile) when using multiple twisted pair cables. Communication distance varies depending on type of cable used.

Use the following formula to determine cable length for specific applications:

$$L = \frac{65 \times 10^6}{(R \times C)} - \frac{(C_i + 10,000)}{C}$$

Where:

- L = length in meters or feet
- R = resistance in Ω (including barrier resistance)
- C = cable capacitance in pF/m or pF/ft
- C_i = maximum shunt capacitance of receiving devices in pF/m or pF/ft

□ PHYSICAL SPECIFICATIONS

Wetted Parts Materials

Diaphragm, Cover flange, Process connector, and Vent/Drain Plug

Refer to 'MODEL AND SUFFIX CODE.'

Capsule Gasket

For wetted parts material code S, Teflon-coated SUS316L.

For wetted parts material code other than S, PTFE(Teflon).

Process Connector Gasket

PTFE Teflon

Fluorinated rubber for Optional code /N2 and /N3

Non-wetted Parts Materials

Bolting

SCM435, SUS630, or SUS660

Housing

Low copper cast-aluminum alloy with polyurethane paint (Munsell 0.6GY3.1/2.0)

Degrees of Protection

IP67, NEMA4X, JIS C0920 immersion proof

Cover O-rings

Buna-N

Name plate and tag

SUS304

Fill Fluid

Silicone, Fluorinated oil (option)

Weight

3.9 kg (8.6 lb) without integral indicator, mounting bracket, and process connector.

Connections

Refer to the model code to specify the process and electrical connection type.

< Settings When Shipped > “◇”

Tag Number	As specified in order *1
Output Mode	'Linear' unless otherwise specified in order
Display Mode	'Linear' unless otherwise specified in order
Operation Mode	'Normal' unless otherwise specified in order
Damping Time Constant *2	'2 sec.'
Calibration Range Lower Range Value	As specified in order
Calibration Range Higher Range Value	As specified in order
Calibration Range Units	Selected from mmH ₂ O, mmAq, mmWG, mmHg, Pa, hPa, kPa, MPa, mbar, bar, gf/cm ² , kgf/cm ² , inH ₂ O, inHg, ftH ₂ O, or psi. (Only one unit can be specified)

- *1: Up to 16 alphanumeric characters (including - and .) will be entered in the amplifier memory.
- *2: If using square root output, set damping time constant to 2 sec. or more.

T07E.EPS

< Related Instruments > “◇”

Power Distributor: Refer to GS 01B04T01-02E or GS 01B04T02-00E

BRAIN TERMINAL: Refer to GS 01C00A11-00E

< Reference >

1. Teflon; Trademark of E.I. DuPont de Nemours & Co.
2. Hastelloy; Trademark of Haynes International Inc.
3. Monel; Trademark of Inco Alloys International, Inc.
4. HART; Trademark of the HART Communication Foundation.
5. FOUNDATION; Trademark of Fieldbus Foundation.

Material Cross Reference Table

SUS316L	AISI 316L
SUS316	AISI 316
SUS304	AISI 304
S25C	AISI 1025
SCM435	AISI 4137
SUS630	ASTM630
SCS14A	ASTM CF-8M

T09E.EPS

< Specification Conformance >

The model EJA110A maintains a specification conformance to at least 3 σ.

MODEL AND SUFFIX CODES

Model	Suffix Codes	Description
EJA110A	Differential pressure transmitter
Output Signal	-D	4 to 20 mA DC with digital communication (BRAIN protocol)
	-E	4 to 20 mA DC with digital communication (HART protocol, refer to GS 01C22T01-00E)
	-F	Digital communication (FOUNDATION Fieldbus protocol, refer to GS 01C22T02-00E)
Measurement span(capsule)	L	0.5 to 10 kPa {50 to 1000 mmH ₂ O}
	M	1 to 100 kPa {100 to 10000 mmH ₂ O}
	H	5 to 500 kPa { 0.05 to 5 kgf/cm ² }
	V	0.14 to 14 MPa { 1.4 to 140 kgf/cm ² } ^{*1}
Wetted parts material	S	[Body] ^{*2} [Capsule] [Vent plug] SCS14A SUS316L ^{*5} SUS316
	H	SCS14A Hastelloy C-276 ^{*6} SUS316
	M	SCS14A Monel ^{*6} SUS316
	T	SCS14A Tantalum ^{*6} SUS316
	A	Hastelloy C-276 equivalent ^{*3} Hastelloy C-276 ^{*6} Hastelloy C-276
	D	Hastelloy C-276 equivalent ^{*3} Tantalum ^{*6} Hastelloy C-276
	B	Monel equivalent ^{*4} Monel ^{*6} Monel
Process connections	0	without process connector (Rc1/4 female on the cover flanges)
	1	with Rc1/4 female process connector
	2	with Rc1/2 female process connector
	3	with 1/4 NPT female process connector
	4	with 1/2 NPT female process connector
	☆ 5	without process connector (1/4 NPT female on the cover flanges)
Bolts and nuts material	☆ A	[Maximum working pressure] SCM435 16 MPa {160 kgf/cm ² } ^{*9}
	B	SUS630 16 MPa {160 kgf/cm ² } ^{*9}
	C	SUH660 16 MPa {160 kgf/cm ² } ^{*9}
Installation	-2	Vertical impulse piping type, right side high pressure, process connector upside ^{*7}
	-3	Vertical impulse piping type, right side high pressure, process connector downside ^{*7}
	-6	Vertical impulse piping type, left side high pressure, process connector upside ^{*7}
	-7	Vertical impulse piping type, left side high pressure, process connector downside ^{*7}
	-8	Horizontal impulse piping type, right side high pressure ^{*8}
	☆ -9	Horizontal impulse piping type, left side high pressure ^{*8}
Electrical connection	☆ 0	G1/2 female, one electrical connection
	2	1/2 NPT female, two electrical connections without blind plug
	3	Pg 13.5 female, two electrical connections without blind plug
	4	M20 female, two electrical connections without blind plug
	5	G1/2 female, two electrical connections and a blind plug
	7	1/2 NPT female, two electrical connections and a blind plug
	8	Pg 13.5 female, two electrical connections and a blind plug
	9	M20 female, two electrical connections and a blind plug
Integral indicator	D	Digital indicator
	E	Digital indicator with the range setting switch ^{*10}
	☆ N	(None)
Mounting bracket	☆ A	SECC Carbon steel 2-inch pipe mounting (flat type)
	B	SUS304 2-inch pipe mounting (flat type)
	C	SECC Carbon steel 2-inch pipe mounting (L type)
	D	SUS304 2-inch pipe mounting (L type)
	N	(None)
Optional codes		/□ Optional specification

T04E.EPS

The '☆' marks indicate the most typical selection for each specification. Example: EJA110A-DMS5A-92NA/□

- *1: For Wetted parts material code H, M, T, A, D, and B, the range limits are 0 to 14 MPa{0 to 140 kgf/cm²}.
- *2: Indicates material of cover flanges and process connectors.
- *3: Indicated material is equivalent to ASTM CW-12MW.
- *4: Indicated material is equivalent to ASTM M35-2.
- *5: Diaphragm material is Hastelloy C-276. Indicated is other wetted parts materials.
- *6: Indicates diaphragm and other wetted parts material.
- *7: If necessary, specify Mounting bracket code C or D.
- *8: If necessary, specify Mounting bracket code A or B.
- *9: For Capsule code L when combined with Wetted parts material code H, M, T, A, D, and B, the maximum working pressure is 3.5 MPa {35 kgf/cm²}.
- *10: Not applicable for Output signal code F.

OPTIONAL SPECIFICATIONS (For Explosion Protected type “◇”)

For FOUNDATION Fieldbus explosion protected type, see GS 01C22T02-00E.

Item	Description	Code
Factory Mutual (FM)	FM Explosionproof Approval *1 *3 Explosionproof for Class I, Division 1, Groups B, C and D Dust-ignitionproof for Class II/III, Division 1, Groups E, F and G Hazardous (classified) locations, indoors and outdoors (NEMA 4X) Temperature class : T6 Amb. Temp. : -40 to 60 °C (-40 to 140 °F)	FF1
	FM Intrinsically safe Approval *1 *3 Intrinsically Safe for Class I, Division 1, Groups A, B, C & D, Class II, Division 1, Groups E, F & G and Class III, Division 1 Hazardous Locations. Nonincendive for Class I, Division 2, Groups A, B, C & D, Class II, Division. 2, Groups E, F & G, and Class III, Division 1 Hazardous Locations. Enclosure : "NEMA 4X", Temp. Class : T4, Amb. Temp. : -40 to 60 °C (-40 to 140 °F) Intrinsically Safe Apparatus Parameters [Groups A, B, C, D, E, F and G] Vmax=30 V, Imax=165 mA, Pmax=0.9 W, Ci=22.5 nF, Li=730 μH [Groups C, D, E, F and G] Vmax=30 V, Imax=225 mA, Pmax=0.9 W, Ci=22.5 nF, Li=730 μH	FS1
	Combined FF1 and FS1 *1 *3	FU1
CENELEC ATEX	CENELEC ATEX (KEMA) Flameproof Approval *2 *3 II 2G EExd IIC T4, T5, T6 Amb. Temp. : T5 ; -40 to 80 °C (-40 to 176 °F), T4 and T6 ; -40 to 75°C (-40 to 167°F) Max. process Temp. : T4 ; 120 °C (248 °F), T5 ; 100 °C (212 °F), T6 ; 85 °C (185 °F)	KF2
	CENELEC ATEX (KEMA) Intrinsically safe Approval *2 *3 II 1G EEx ia IIC T4, Amb. Temp. : -40 to 60 °C(-40 to 140 °F) Ui=30 V, Ii=165 mA, Pi=0.9 W, Ci=22.5 nF, Li=730 μH	KS2
	Combined KF2, KS2 and Type n *2 *3 Type n: II 3G Ex nL IIC T4, Amb. Temp.: -40 to 60 °C (-40 to 140 °F) Ui=30 V DC, Ci=22.5 nF, Li=730 μH	KU2
Canadian Standards Association (CSA)	CSA Explosionproof Approval *1 *3 Explosionproof for Class I, Division 1, Groups B, C and D Dustignitionproof for Class II/III, Division 1, Groups E, F and G Division2 'SEALS NOT REQUIRED', Temp. Class : T4, T5, T6 Encl Type 4x Max. Process Temp. : T4 ; 120 °C (248 °F), T5 ; 100 °C (212 °F), T6 ; 85 °C (185 °F) Amb. Temp. : -40 to 80 °C (-40 to 176 °F)	CF1
	CSA Intrinsically safe Approval *1 *3 Class I, Groups A, B, C and D Class II and III, Groups E, F and G Encl Type 4x, Temp. Class : T4, Amb. Temp. : -40 to 60 °C (-40 to 140 °F) Vmax=30 V, Imax=165 mA, Pmax=0.9 W, Ci=22.5 nF, Li=730 μH	CS1
	Combined CF1 and CS1 *1 *3	CU1
Standards Association of Australia (SAA)	SAA Flameproof, Intrinsically safe and Non-sparking Approval *3 *4 Ex d IIC T4/T5/T6, IP67, Amb. Temp. : -40 to 80 °C (-40 to 176 °F) Max. Process Temp. : T4 ; 120 °C (248 °F), T5 ; 100 °C (212 °F), T6 ; 85 °C (185 °F) Ex ia IIC T4, IP67 Ex n IIC T4, IP67 Ui=30 V DC, Ii=165 mA DC, Wi=0.9 W, Amb. Temp. : -40 to 60 °C (-40 to 140 °F)	SU1

T06E.EPS

- *1: Applicable for Electrical connection code 2 and 7 (1/2 NPT female).
- *2: Applicable for Electrical connection code 2, 4, 7 and 9 (1/2 NPT and M20 female).
- *3: Applicable for Output signal code D and E.
For intrinsically safe approval, use the safety barrier certified by the testing laboratories (BARD-400 is not applicable).
- *4: Applicable for Electrical connection code 2, 3, 4, 7, 8 and 9 (1/2 NPT, Pg 13.5, and M20 female).

OPTIONAL SPECIFICATION

Item		Description	Code	
Painting	Color change	Amplifier cover only	P□	
	Coating change	Epoxy resin-baked coating	X1	
Lightning protector		Transmitter power supply voltage: 10.5 to 32 V DC (10.5 to 30 V DC for intrinsically safe type, 9 to 32 V DC for Fieldbus communication type.) Allowable current: Max. 6000 A (1×40 μs), Repeating 1000 A (1×40 μs) 100 times	A	
Oil-prohibited use *6		Degrease cleansing treatment	K1	
		Degrease cleansing treatment and with fluorinated oilfilled capsule. Operating temperature -20 to 80°C	K2	
Oil-prohibited use with dehydrating treatment *6		Degrease cleansing treatment and dehydrating treatment	K5	
		Degrease cleansing treatment and dehydrating treatment with fluorinated oilfilled capsule. Operating temperature -20 to 80°C	K6	
Calibration units *1		P calibration (psi unit)	(See Table for Span and Range Limits.) D1	
		bar calibration (bar unit)		D3
		M calibration (kgf/cm ² unit)		D4
Sealing treatment to SUS630 nuts		Sealant(liquid silicone rubber) is coated on JIS SUS630 cover flange mounting nuts against stress corrosion cracking.	Y	
Long vent *2		Total length: 119 mm (standard: 34 mm); Total length when combining with Optional code K1, K2, K5, and K6: 130 mm. Material: SUS316.	U	
Fast response *7		Update time: 0.125 sec or less Amplifier damping time constant: 0.1 to 64 sec in 9 increments Response time (with min. damping time constant): max. 0.5 sec (for L capsule: max. 0.6 sec)	F1	
Failure alarm down-scale *3		Output status at CPU failure and hardware error is -5%, 3.2 mA or less.	C1	
NAMUR NE43 compliant *3 *9		Output signal limits: 3.8 mA to 20.5 mA	Failure alarm down-scale: output status at CPU failure and hardware error is -5%, 3.2 mA or less.	C2
			Failure alarm up-scale: output status at CPU failure and hardware error is 110%, 21.6 mA or more.	C3
Stainless steel amplifier housing *4		Amplifier housing material: SCS14A stainless steel (equivalent to SUS316 cast stainless steel or ASTM CF-8M)	E1	
Gold-plate *5		Surface of isolating diaphragms are gold plated, effective for hydrogen permeation.	A1	
Configuration		Custom software configuration	R1	
Body option *8		Without drain and vent plugs	N1	
		N1 and Process connection, based on DIN 19213 with 7/16 inch×20 unf female thread, on both sides of cover flange with blind kidney flanges on back	N2	
		N1, N2, and Mill certificate for cover flange, diaphragm, capsule body, and blind kidney flange	N3	
Stainless steel tag plate		SUS304 stainless steel tag plate wired onto transmitter	N4	

T06E.EPS

- *1: The unit of MWP (Max. working pressure) on the name plate of a housing is the same unit as specified by Optional code D1, D3, and D4.
- *2: Applicable for vertical impulse piping type (Installation code 2, 3, 6, and 7) and Wetted parts material code S, H, M, and T. Long vent material is SUS316.
- *3: Applicable for Output signal code D and E. The hardware error indicates faulty amplifier or capsule. When combining with Optional code F1, output status for down-scale is -2.5%, 3.6 mA DC or less.
- *4: Applicable for Electrical connection code 2, 3, 4, and 7. Not applicable for Optional code P□ and X1.
- *5: Applicable for Wetted parts material code S.
- *6: Applicable for Wetted parts material code S, H, M, and T.
- *7: Applicable for Output signal code D and E. Consult Yokogawa when combining with Optional code for explosion protected type.
- *8: Applicable for Wetted parts material code S, H, T, and M; Process connection code 3, 4, and 5; Installation code 9; and Mounting bracket code N. Process connection faces on the other side of zero adjustment screw.
- *9: Not applicable for Optional code C1.

Item	Description		Code
Mill Certificate	Cover flange *1		M01
	Cover flange, Process connector *2		M11
Pressure test/ Leak test Certificate	Test Pressure: 3.5 MPa{35 kgf/cm ² } ^{*3}	Nitrogen(N ₂) Gas ^{*5}	T01
	Test Pressure: 16 MPa{160 kgf/cm ² } ^{*4}	Retention time: 10 minutes	T12

T10E.EPS

- *1: Applicable for Process connections code 0 and 5.
- *2: Applicable for Process connections code 1, 2, 3, and 4.
- *3: Applicable for Capsule code L when combined with Wetted parts material code H, M, T, A, D, and B.
- *4: Applicable for Capsule code M, H, and V and Capsule code L when combined with Wetted parts material code S.
- *5: Pure nitrogen gas is used for oil-prohibited use (Optional code K1, K2, K5, and K6).

DIMENSIONS

● **Model EJA110A**

Vertical Impulse Piping Type

Process connector upside (INSTALLATION CODE '6') (For CODE '2' or '3,' refer to the notes below.)

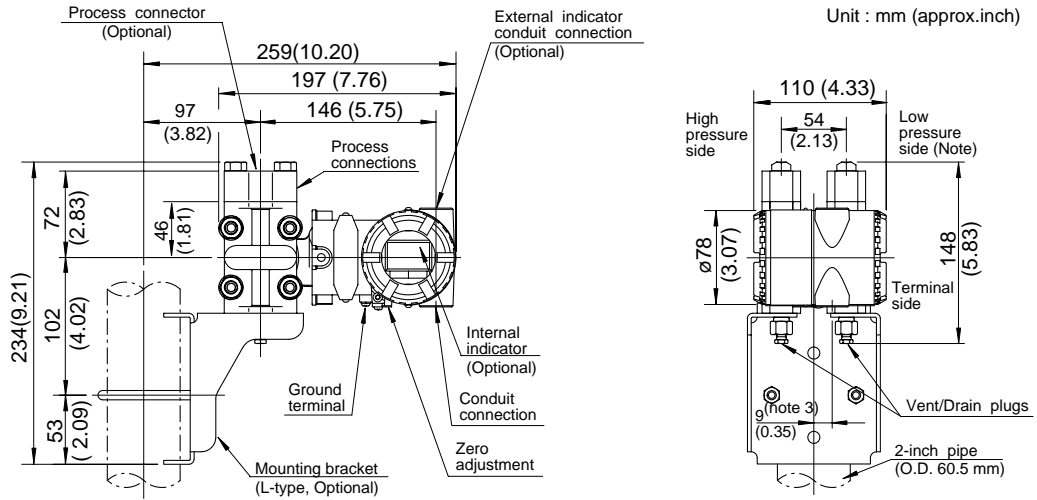

Process connector downside (INSTALLATION CODE '7')

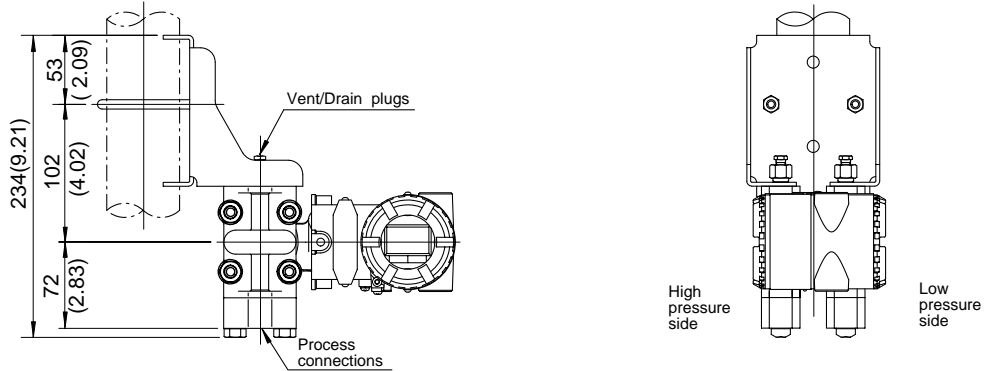

Horizontal Impulse Piping Type (INSTALLATION CODE '9') (For CODE '8', refer to the notes below.)

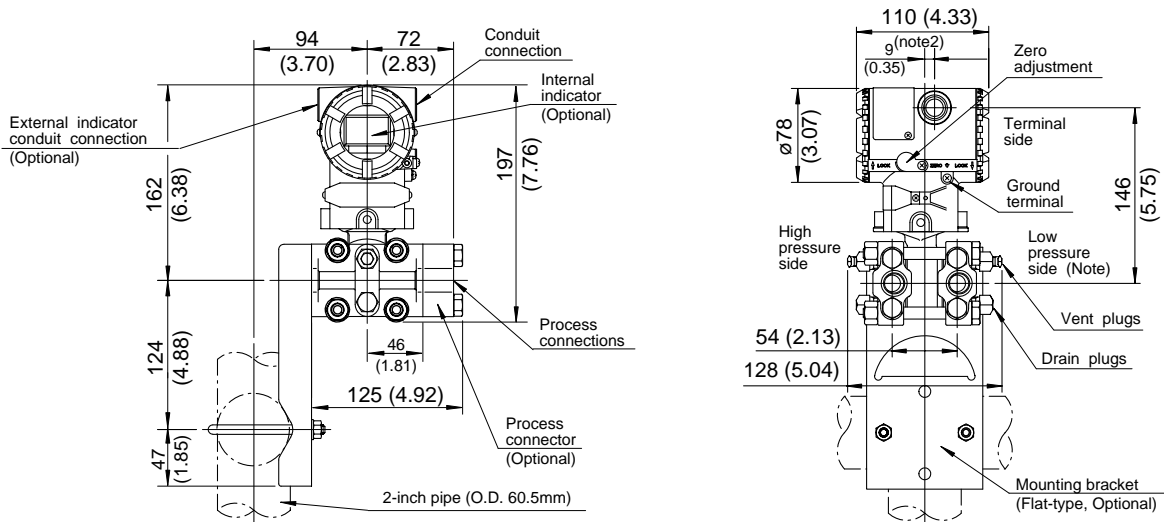

* 1: When Installation code 2, 3, or 8 is selected, high and low pressure side on above figure are reversed. (i.e. High pressure side is on the right side.)
 * 2: 15 mm(0.59 inch) for right side high pressure.(for code 2, 3 or 8)

F03E.EPS

● Terminal Configuration

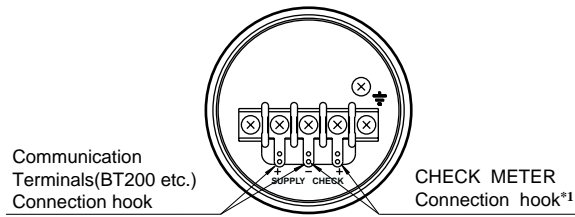

● Terminal Wiring

SUPPLY \pm	Power supply and output terminal
CHECK \pm	External indicator(ammeter) terminal*1
---	Ground terminal

*1: When using an external indicator or a check meter, the internal resistance must be 10 Ω or less. Not available for Fieldbus communication(Output signal code F).
FO5E.EPS

■ SELECTION GUIDE

Application	Type	Model	Capsule	Measurement Span		Maximum Working Pressure	
				kPa	inH ₂ O	MPa	psi
Differential Pressure	Traditional-Mounting*1	EJA110A	L	0.5 to 10	2 to 40	16 ^{*4}	2250 ^{*4}
			M	1 to 100	4 to 400	16	2250
			H	5 to 500	20 to 2000	16	2250
			V	0.14 to 14MPa	20 to 2000 psi	16	2250
Flow	Integral Orifice	EJA115	L	1 to 10	4 to 40	3.5	500
			M	2 to 100	8 to 400	14	2000
			H	20 to 210	80 to 830	14	2000
Differential Pressure & Liquid Level with Remote Seals	Extended Flush Combination	EJA118N EJA118W EJA118Y	M	2.5 to 100	10 to 400	Based on Flange Rating	
			H	25 to 500	100 to 2000		
Draft Range	Traditional-Mounting*1	EJA120A	E	0.1 to 1	0.4 to 4	50 kPa	7.25
Differential Pressure & Liquid Level	Traditional-Mounting*1	EJA130A	M	1 to 100	4 to 400	32	4500
			H	5 to 500	20 to 2000	32	4500
Liquid Level, Closed or Open Tank	Flush Extended	EJA210A EJA220A	M H	1 to 100 5 to 500	4 to 400 20 to 2000	Based on Flange Rating	
Absolute (vacuum) Pressure	Traditional-Mounting*1	EJA310A	L	0.67 to 10 ^{*2}	2.67 to 40 ^{*2}	10 kPa ^{*2}	40 in H ₂ O ^{*2}
			M	1.3 to 130 ^{*2}	0.38 to 38 inHg ^{*2}	130 kPa ^{*2}	18.65 ^{*2}
			A	0.03 to 3 MPa ^{*2}	4.3 to 430 psi ^{*2}	3000 kPa ^{*2}	430 ^{*2}
Gauge Pressure	Traditional-Mounting*1	EJA430A	A	0.03 to 3 MPa	4.3 to 430 psi	3	430
			B	0.14 to 14	20 to 2000 psi	14	2000
Gauge Pressure with Remote Seal	Extended	EJA438N	A B	0.06 to 3 MPa 0.46 to 7	9 to 430 psi 66 to 1000 psi	Based on Flange Rating	
Gauge Pressure with Remote Seal	Flush	EJA438W	A B	0.06 to 3 MPa 0.46 to 7	8 to 430 psi 66 to 2000 psi	Based on Flange Rating	
High Gauge	Traditional-Mounting*1	EJA440A	C	5 to 32 MPa	720 to 4500 psi	32	4500
			D	5 to 50 MPa	720 to 7200 psi	50	7200
Absolute & Gauge Pressure*3	Direct-Mounting	EJA510A EJA530A	A	10 to 200	1.45 to 29 psi	200 kPa	29
			B	0.1 to 2 MPa	14.5 to 290 psi	2	290
			C	0.5 to 10 MPa	72.5 to 1450 psi	10	1450
			D	5 to 50 MPa	720 to 7200 psi	50	7200

TO8E.EPS

*1: Traditional-mounting is 1/4 - 18 NPTF process connections (1/2 - 14 NPTF with process adapters) on 2-1/8" centers.

*2: Measurement values in absolute.

*3: Measurement values in absolute for EJA510A.

*4: When combined with Wetted parts material code H, M, T, A, D, and B, the value is 3.5 MPa (500 psi).

< Ordering Information > “◇”

Specify the following when ordering

1. Model, suffix codes, and optional codes
2. Calibration range and units:
 - 1) Calibration range can be specified with range value specifications up to 5 digits (excluding any decimal point) for low or high range limits within the range of -32000 to 32000.
 - 2) Specify only one unit from the table, 'Settings when shipped.'
3. Select linear or square root for output mode and display mode.

Note: If not specified, the instrument is shipped set for linear mode.

4. Select normal or reverse for operation mode

Note: If not specified, the instrument is shipped in normal operation mode.

5. Display scale and units (for transmitters equipped with integral indicator only)

Specify either 0 to 100 % or engineering unit scale and 'Range and Unit' for engineering units scale: Scale range can be specified with range limit specifications up to 5 digits (excluding any decimal point) for low or high range limits within the range of -19999 to 19999.
6. Tag Number (if required)